

**USER'S GUIDE AND  
TECHNICAL REFERENCE**

**AC SOURCE**

**BEHLMAN MODEL BL6000 SERIES**

**PART NUMBER: \_\_\_\_\_**

**MODEL \_\_\_\_\_**

**FOR SERVICE ASSISTANCE**

CONTACT BEHLMAN  
CUSTOMER SERVICE DEPARTMENT

PHONE TOLL FREE 1-800-874-6727

**OR WRITE**

BEHLMAN  
CUSTOMER SERVICE DEPARTMENT  
80 CABOT COURT  
HAUPPAUGE, NY 11788

PHONE: (631) 453-0410

FAX : (631) 951-4341

**FOR SALES INFORMATION:**

PHONE: (631) 435-0410

USA : (800) 874-6727

FAX : (631) 951-4341

# **PACKING INSTRUCTIONS**

## **RACK MOUNTED UNITS**

- 1) Box (es) must be double wall with minimum 350 lbs. bursting test.
- 2) Box (es) must provide for a minimum of 2 to 3 inches of clearance around sides, top and bottom of unit.
- 3) When packing unit, utilize either a foam-in-place system or high density foam. Clearance provided for above must be completely filled with foam.

**FAILURE TO COMPLETELY SECURE UNIT IN BOX WILL ALLOW  
MOVEMENT DURING SHIPPING, RESULTING IN DAMAGE.**

**DO NOT USE PEANUTS OR BUBBLE**

- 4) Secure box (es) to pallet (s). This is necessary to insure proper handling and protection during shipping.
- 5) Place the following warning label on box (es)

**DO NOT STACK**

- 6) Ship unit (s) using a freight cargo carrier; air or ground.

**DO NOT USE UPS**

## **CABINET MOUNTED UNITS**

Cabinet mounted units require that a special crate be used. The crate should be manufactured of plywood (3/8" or thicker) and reinforced (using 1 x 3 or larger pine) on all edges. The unit must be firmly secured to the crates base. The crate must be shock mounted to avoid damage during shipping.

Detail drawings for Behlman's crates are available upon request.

## TABLE OF CONTENTS

### BEHLMAN AC SOURCE, MODEL SERIES BL6000

#### SECTION

#### **1 INTRODUCTION**

- 1.1 General Description
- 1.2 Options
- 1.3 Special Units
- 1.4 Specifications

#### **2 UNPACKING AND INSTALLATION**

- 2.1 Unpacking
- 2.2 Installation
- 2.3 Installation and input requirements ( 3 phase power )
- 2.4 Installation and input requirements ( single phase power )
- 2.5 Supplemental input protection.
- 2.6 T6 and T6D options
- 2.7 Installation Considerations

#### **3 OPERATION**

- 3.1 Controls and Indicators
- 3.2 To Operate The Equipment
- 3.3 Shutdown Procedure
- 3.4 Line Drop Compensation
- 3.5 Remote Programming
- 3.6 External Sync
- 3.7 Operational Considerations

#### **4 MAINTENANCE AND ADJUSTMENTS**

- 4.1 Maintenance
- 4.2 Adjustments

#### **5 THEORY OF OPERATION**

- 5.1 General
- 5.2 Input Power
- 5.3 Control Chassis
- 5.4 Motherboard
- 5.5 Output Invertor
- 5.6 Metering
- 5.7 Miscellaneous

**TABLE OF CONTENTS (cont)**

**BEHLMAN AC SOURCE, MODEL SERIES BL6000**

	<b>DESCRIPTION</b>	<b>DOCUMENT NUMBER</b>
<b>6</b>	<b>DRAWINGS</b>	
	Control Chassis (Assembly) .....	106-909-006*
	Control Chassis (Schematic) .....	106-951-015/017
	Motherboard (Schematic) .....	106-948-000*
	Phase Control - (Schematic) .....	106-942-000*
	Power Chassis ( Assembly) 3 phase .....	106-977-1XX*
	Power Chassis ( schematic 3 phase) .....	106-956-006
	Power Chassis ( schematic 1 phase) .....	106-956-009
	Outline Control Chassis .....	106-909-508
	Outline Drawing, Input Chassis (3 phase) .....	106-977-500*
	Outline Drawing ,Input Chassis ( single phase) .....	106-909-514*

\*NOTE: some drawings are common to other model series.

**APPENDIX**

<b>A</b>	IGBT Driver .....	<b>A-1</b>
<b>B</b>	IEEE- 488 Remote Interface Operation .....	<b>B-1</b>
<b>C</b>	RS232 Remote Interface Operation .....	<b>C-1</b>

## **CLAIM FOR DAMAGE IN SHIPMENT**

Under the FOB factory terms of sale, ownership and responsibility are transferred to the customer when the equipment leaves the factory. Each Behlman equipment is shipped from the factory in proper operating condition.

Immediately upon receiving equipment, unpack and inspect it for evidence of damage incurred in shipment. File a claim with the freight carrier if the equipment has been damaged in any way or it fails to operate properly. Forward a copy of the damage claim report to Behlman. Include the model number, serial number and date the shipment was received. Behlman will advise the disposition of the equipment and will arrange for necessary repair or replacement.

## **RETURNING EQUIPMENT TO FACTORY**

Do not return equipment to the factory without prior authorization from Behlman.

This equipment, like all precision electronic equipment, is susceptible to shipping damage. It contains heavy magnetic components as well as delicate electronic components.

If equipment is returned without prior authorization, the shipment will be refused, the customer being liable for all shipping, handling and repair costs.

When packing for reshipment, use the original shock absorbent material and shipping container to preclude damage to the equipment.

Insure that the return authorization numbers (RMA) is available on the container.

## SECTION 1

### INTRODUCTION

#### 1.1 GENERAL DESCRIPTION

The Behlman BL6000 AC Source models (table 1) are sophisticated ac power supplies. These devices convert the available utility power to a voltage and frequency required by the end user. Regulation and control of the AC power is also provided by these devices. Each of the models provide independent verification of operating voltage, current, and frequency values thereby lessening the need for external measuring devices.

All Behlman BL series power supplies are based on high frequency, pulse width modulated, IGBT technology. This arrangement provides a highly efficient power conversion scheme in a compact size. These devices are used in many applications including; avionics testing, production ATE, processes control, research and development, and anywhere ac power ( other than utility power) is required.

#### 1.2 OPTIONS

The Behlman 6000 series is available with many input and output options. Some of the output options require additional transformer chassis for higher voltages. The table and list below summarizes these options. Any of the models can include all or any combination of the available options if desired.

**TABLE 1. BEHLMAN 6000 SERIES MODELS**

MODEL	INPUT VOLTAGE (ac)	OUTPUT VOLTAGE (ac)
BL6000C-1	120V/208V/ 3 $\phi$	0 - 270, 1 $\phi$
BL6000C-2	220V/380V/ 3 $\phi$	0 - 270V,1 $\phi$
BL6000C-3	277V/480V/ 3 $\phi$	0 - 270V, 1 $\phi$
BL6000C-4	200V $\Delta$ / 3 $\phi$	0 - 270V, 1 $\phi$
BL6000C-5	346V/600V/ 3 $\phi$	0 - 270V, 1 $\phi$
BL6000C-6	230V/400V/ 3 $\phi$	0 - 270V, 1 $\phi$
BL6000C-7	240V/415V/ 3 $\phi$	0 - 270, 1 $\phi$
BL6000C-8	120V 1 $\phi$ *	0 - 270V,1 $\phi$
BL6000C-9/10	240/480V 1 $\phi$ *	0 - 270V,1 $\phi$

\*Note : All single phase input requires a floor mounted cabinet. All others are comprised of one 7" chassis and one 10.5" rack chassis( except special options.)

OPTIONS: Add E to the dash number for extended frequency range.  
Add I to the dash number for Remote GPIB IEEE-488 Interface.  
Add L to the dash number for front panel locking controls (VOLTS, FREQ)  
Add S10 to the dash number for chassis slides.  
Add T6 to the dash number for custom voltage ranges may add additional chassis.  
Add T3D to the dash number for dual voltage ranges 0-135/300 add 7.0" chassis.  
Add CE to the dash number for voltage ranges for CE mark.

### 1.3 SPECIAL UNITS

BEHMAN has produced many special versions of the BL series supplies over the years and will continue to offer specials to our customers. These specials are usually in the form of customer specified output voltages, special control functions, or special waveforms ( square wave is one example ). With this in mind it should be noted some of the information ( including specifications) contained in this manual may not be applicable to the unit shipped.

All special units will be designated by a four digit “engineering” number following the model number indicated on the power supply rating tag ( identification label). This number refers to an engineering file that contains modification instructions and (or) drawings related to the special unit. This information may or may not be included in this manual. Unless specified by purchase contract, the decision to include this information in this manual is reserved solely by Behlman .

All special unit manuals will include an addendum that explains the modification and refers to any special operating considerations warranted by the modification. Any exceptions to standard unit specifications will also be addressed by the addendum. When ordering replacement or additional manuals , make sure to check the ID label for the power supply so that any addendums may be included.

CE marked units are available and may include additional filtering ( on input line) as well as “anti EMI” cable assemblies added to various parts of the units. Units certified with “CE” mark will the following additions:

- |    |                           |  |
|----|---------------------------|--|
| 1. | Input line filter         | Behlman P/N 108-115-040  |
| 2. | Various Ferrite Inductors | Behlman P/N 110-012-001<br>Behlman P/N 110-013-005 & 110-013-019 |

The Ferrite inductors are added to input and output wiring of the control chassis. The line filter is added to the input chassis. All other parts and specifications are un-changed.

**ALL MANUAL ADDENDUMS WILL FOLLOW THIS PAGE**

**THIS PAGE BLANK FOR ADDENDUMS**



---

## 1.4 SPECIFICATIONS

---

### INPUT POWER

Voltage: see chart on preceding page

Frequency: 47-63 Hz.

### OUTPUT POWER

Voltage: 0-270 Vac, 1 $\phi$  \* ( standard )

Frequency: 45-500 Hz ( 45 to 1KHz for E option units )

Maximum Power: 6000 VA

Maximum Current: 22 amperes ( standard models )

Current Crest  
Factor: 3:1.

Power Factor: 100% of rated output into any power factor load.

Distortion: 1.5% maximum THD (measured at full load, 100 Vac, 50 Hz).

Load Regulation:  $\pm 0.7\%$  from no load to full load.

Line Regulation:  $\pm 0.1\%$  for  $\pm 10\%$  of line change.

Efficiency: 85-90% ( with 3 phase input )

### MECHANICAL

Dimensions: standard EIA 19 in. rack wide, 17.5in. high, 22 in. deep .( 3 phase in with no options.)

Weight: 150 lbs. ( 3 phase inputs with no options )

Operating  
Temperature: 0°C to 55°C (32°F to 131°F).

\* Voltage may vary. See option list, page 1.

## SECTION 2

### UNPACKING AND INSTALLATION

#### 2.1 UNPACKING

After unpacking the AC Source (unit), carefully conduct a thorough inspection of controls, indicators and chassis. If the unit shows signs of damage, do not attempt to operate. File a damage claim with the carrier responsible. Notify Behlman immediately.

#### 2.2 INSTALLATION

- 1) **This device must be installed and operated by qualified persons only. The content of this manual must be reviewed prior to use.**
- 2) This unit is designed to be rack mounted. The unit must have bottom support when mounting in a rack or a cabinet. Do not attempt to mount by front panels only. These units, when stacked, require proper cooling air circulation, one inch clearance between units and a six inch clearance at the rear of the units.
- 3) Ensure that the line circuit breaker and all other unit controls are in the OFF position before connecting input power. Use **only** the lower screws when connecting wires to the control chassis terminal block. Turn the upper screw will loosen internal hardware and will cause damage to the unit.
- 4) Connect 3 phase units as follows: ( refer to inter-connect diagrams provided on following pages.)
  - a) INPUT POWER- Connect 47-63 Hz, power lines to the designated terminals,  $\phi A$ ,  $\phi B$ ,  $\phi C$ , and neutral ( required for all inputs above 240V L-N ) on the INPUT terminal strip of the power chassis.
  - b) OUTPUT POWER- Output power lines are connected to the "Hi" , and "LO" positions provided on the output terminal strip of the control chassis (output chassis "T" option).
  - c) Interconnection between chassis:  
Connect HI, GND, and LOW of power chassis to HI, GND, and LOW of control chassis with cable provided. Connect the two chassis together by connecting their GND studs with cable provided. Single phase units have hardwired DC connections and are factory connected to the control chassis.
  - d) On all units, a chassis connected stud is provided to connect a safety earth to each metal chassis. **This connection is required to provide operator safety** and reduce EMI emissions.

#### IMPORTANT NOTE:

If this unit is to be installed as part of a permanent power source with wiring distributed in a building the user is responsible for conformance to local electrical codes . The National Electrical Code (NEC),section 250 , requires that all separately derived AC power sources ( generators, invertors, etc.) must have one conductor tied to earth. This is similar to the concept of the neutral conductor in domestic power distribution systems. This connection may be provided by connecting the input neutral to the output neutral or connecting the output neutral to the chassis ground ( assuming the chassis is tied to earth). See figure 2-4 . Consult local codes and a qualified electrician.

### 2.3 3 PHASE INPUT POWER REQUIREMENTS

The BL6000 series power supplies within the model number range C2 to C6 are designed to be used with a four wire “Wye” input configurations. Units that are to be supplied with “Delta” inputs above 277 volts require the use of “back-up” fuses to provide supplemental protection. This is due to the interrupt rating of the circuit breaker used. The chart below indicates the proper fuse based on the model number of the power supply. This chart can also serve as a guide for sizing the input service to the unit. Note: refer to the following section for C8/9/10 ( single phase input models ).

The following lists should be used to select the proper line fuse size for the model numbers shown. The selections are based on nominal line voltages and maximum output power. All fuses carry a 600 Vac rating. DO NOT substitute any other fuse type.

MODEL #	L-L VOLTAGE	FUSE SIZE	PART NUMBER
BL 6000 - C2	380V	25AMP / 600V	108-201-021
BL 6000- C3	480V	20 AMP/ 600V	108-201-020
BL 6000- C5	600 V	20 AMP/ 600V	108-201-020
BL 6000- C6	400V	25 AMP/ 600V	108-201-020

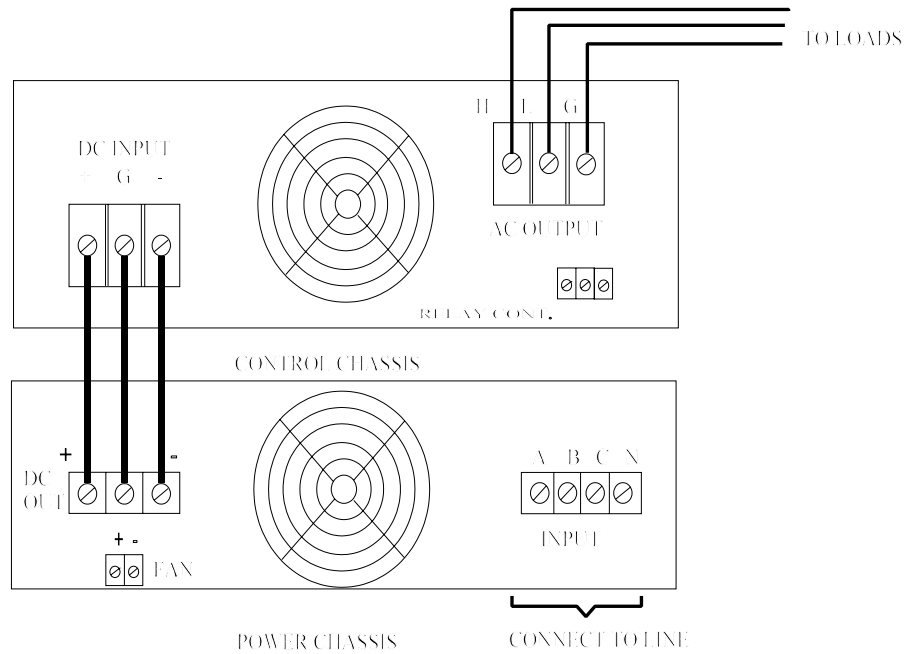

Figure 2-1 . Inter-connect diagram for standard 3 phase input.

## 2.5 INPUT POWER CONSIDERATIONS ( For C8 , C9, and C10 single phase input units )

This device utilizes a single phase, full wave, rectifier followed by a capacitive filter to provide main operating voltages. This type of arrangement produces an input current with a high harmonic content. These harmonics contribute to the input current requirement but do not contribute to the output power. This fact equates to the input of this device having a low power factor. Power factor is the ratio of input volt-amperes ( apparent power) to real power (watts) consumed. The power factor of a single phase rectifier ( with capacitive filter) is on the order of 0.6 to 0.8 depending on the line impedance and condition of the capacitors used ( typically electrolytic).

The power factor of this unit should not be confused with the stated output efficiency of 80%. This rating deals with the inverter efficiency and is measured with a 3 phase input that yields a power factor closer to 0.90. In order to select the proper electrical service size for this unit, the total power consumption and input power factor must be considered. What follows below is a typical example.

The following is assumed:

Output power is in real watts at an efficiency of 80%.

Total power equals  $6000 \text{ W} / 0.8 = 7500 \text{ watts}$

Assuming a worst case power factor of 0.6 a multiplication factor of 1/PF can be used to find the total input volt-amperes:

$$7500 \times 1.66 = 12,450 \text{ VA}$$

If operating at 240 Vac ( 216 V @ 10% low line ) input then the input current requirement is :

$$12,450 / 216\text{V} = 57.6 \text{ amperes}$$

The actual input current will be somewhat lower depending on the line impedance in series with the power supply. Also, if the load being powered is reactive, the actual input current could be considerably lower. Testing under actual conditions may yield results allowing the use of a smaller service. **Consultation with an experienced electrician or plant engineer is highly recommended.**

### 2.5.1 SUPPLEMENTAL PROTECTION FOR 480V SINGLE PHASE INPUTS.

Single phase units supplied with higher than 277 inputs require back-up fuses for proper protection. These fuses should be rated at least 600V at a current rating of 30 amps. The fuse interrupt rating is dependant on the application. Consultation with an experienced electrician is recommended.

## 2.5.2 WIRING FOR SINGLE PHASE INPUTS

Units supplied with single phase inputs are shipped in a rack cabinet that is an integral part of the power unit. These units are shipped pre-wired. The end user connections are made through access holes at the bottom rear of the unit. A terminal block for input power is provided next to the access hole. The output wiring is connected to the control chassis as in the standard configuration. Single phase units with the T6 or T6D option will have an additional terminal block for connecting output wiring. The figure below illustrates the external wiring for single phase units. Note that a door or panel will need to be removed/opened for wiring access. Actual cabinet may vary from figure below.

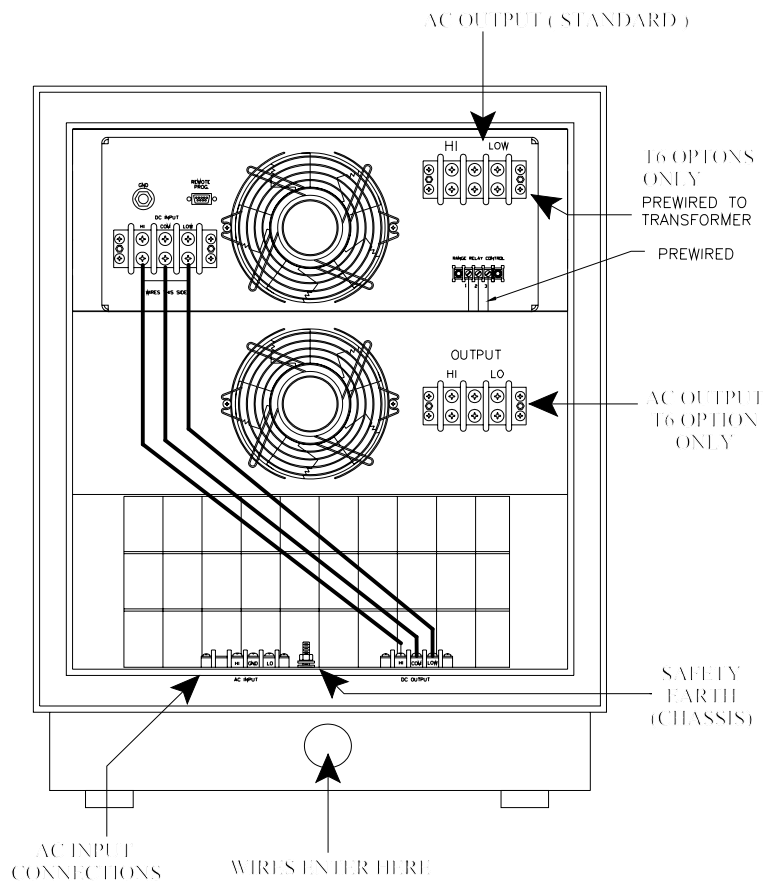

BL6000 SINGLE PHASE INPUT REAR VIEW WITH COVERS REMOVED

Figure 2-2 Single phase inputs

## 2.6 UNITS WITH T6 OR T6D OPTIONS

The diagram below illustrates chassis inter-connection for units provided with the T6 or T6D options. The T6D units are dual range versions of the standard T6 type. As shown below this option includes an additional 7.0 inch high chassis to house the external transformers and range relay for T6D units.

Units supplied with T6 options may vary slightly depending on actual customers requirements. Units with a or 0 to 300 Vac output are considered standard. Units supplied with other voltages will be assigned a 4 digit engineering number. T6 units require some special operating considerations.

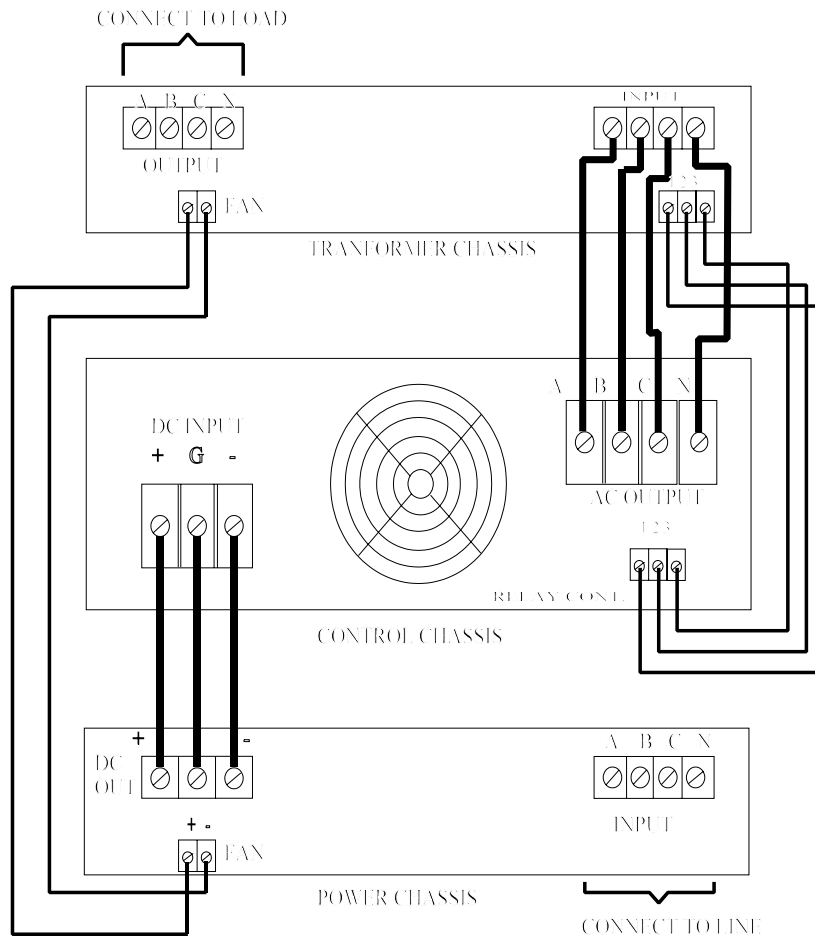

Refer to section 3 of this manual for operating instructions.

Figure 2-3. T6 option interconnect

## 2.7 Installation Considerations

This device relies on the proper flow of air to provide internal cooling. Failure to provide this will cause intermittent shut down of the unit due to overheating and will affect the long term reliability. Air is taken into to the unit through “grills” in the front and side of the unit. A distance of at least 6 inches must be maintained between the front intake and any obstruction. Likewise, the heated air is exhausted through grills in the rear panel. A distance of four inches is required between the rear panel and any obstruction to prevent “back pressure” from reducing air flow.

This device is intended for use in a relatively clean environment . For this reason, air filters are not provided on the intakes. If air filtering is desired, it may be added at the expense of reduced air flow. This may result in some required de-rating of the output power available from this unit.

An additional “stud” has been included on the rear panel of this device. This point may be used for a safety earth connection to the chassis. This is a convenient tie point for a “bonding” conductor or other chassis grounding arrangement. Refer to figure 2-4 below.

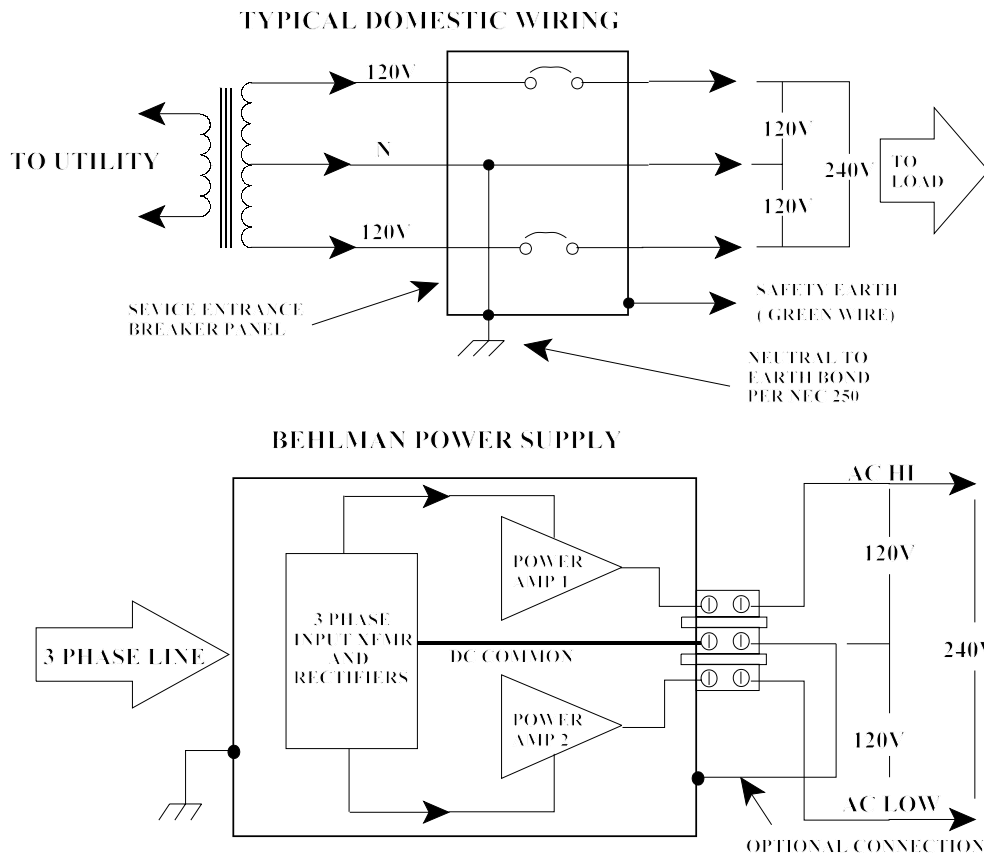

Figure 2-4

## **SECTION 3**

### **OPERATION**

#### ***WARNING***

**This equipment involves the use of voltages and currents that can be hazardous. Only qualified personnel should be allowed to operate or service it. The top cover(s) must always be in place during operation.**

#### **3.1 CONTROLS AND INDICATORS**

Table 1 lists the controls and indicators used on the different models of the AC Source. The table also includes their function. Figure 3-1 locates these front panel controls and indicators. Also shown are the rear panel REMOTE PRGM connector, two terminal strips, cooling fan, and a GND stud.

#### **3.2 TO OPERATE THE EQUIPMENT**

- 1) Ensure that line circuit breaker and OUTPUT switch are set to OFF.
- 2) Connect suitable load across output terminals. (Do not exceed rating of unit.)
- 3) Set line circuit breaker of power chassis to ON (cooling fan noise should become evident).
- 4) Rotate VOLTS control to desired voltage. ( for T6D units, set range switch as required).
- 5) Rotate FREQ control to desired frequency.
- 6) Set OUTPUT switch to ON to energize load.

#### **NOTE**

It is permissible to energize a load gradually by setting the OUTPUT switch ON and rotating the VOLTS control from zero to low voltage position up to the voltage desired.

#### **3.3 SHUTDOWN PROCEDURE**

- 1) Set OUTPUT switch to OFF.
- 2) Set line circuit breaker to OFF.

#### **3.4 ADJUSTMENT OF LINE DROP COMPENSATION**

- 1.) With the Unit on and stabilized, note the voltage indication on the front panel meter. Apply a load and use an external voltmeter(as close to the load as practical) to measure the voltage supplied to the load terminals.
- 2.) Using an insulated screwdriver, adjust the front panel "LINE DROP COMP" to bring the load terminal voltage to the same value as that indicated by the unit. This will compensate for I/R drops due to the load wiring. Note, Line drop comp will not work without a load applied.



TABLE 3-1. CONTROLS AND INDICATORS

REF	CONTROL/INDICATOR	FUNCTION
1	Circuit breaker	ON: Connects input power to unit. OFF: Disconnects input power from unit.
2	CONSTANT CURRENT indicator	Lights to indicate protective circuits are automatically operating to provide rated current and distortion-less output during an overload condition.
3	" <b>FREQ</b> " control	Used to establish output frequency.
4	<b>OUTPUT</b> switch	ON: Connects output power to control chassis rear panel output terminals. OFF: Disconnects output power at rear panel.
5	OVERLOAD LATCH indicator	Lights to indicate short circuit protection for overload conditions that disables the output. Overload latch is reset by removing load and recycling power.
6	OVER-TEMP indicator	Lights to indicate over temperature condition and removal of output power. Output power is automatically restored on termination of over-temperature condition.
7	Digital readout meters	VOLTS: Provides output voltage (RMS) display. AMPS: Provides output current (RMS) display. FREQ: Provides output frequency display.
8	" <b>VOLTS</b> " control	Used to establish desired output voltage.
9	Line drop compensation	Allows for output adjustment due to IR drops in the load lines.
10	Output RANGE switch ( T6D option only)	Selects output voltage range
11	DC Power input Terminal block	Connect to +/-250VDC from power section.
12	AC output terminal block	Connects AC output to user's load.
13	Remote Connectors	Analog, IEEE-488 , or RS-232 control ports.

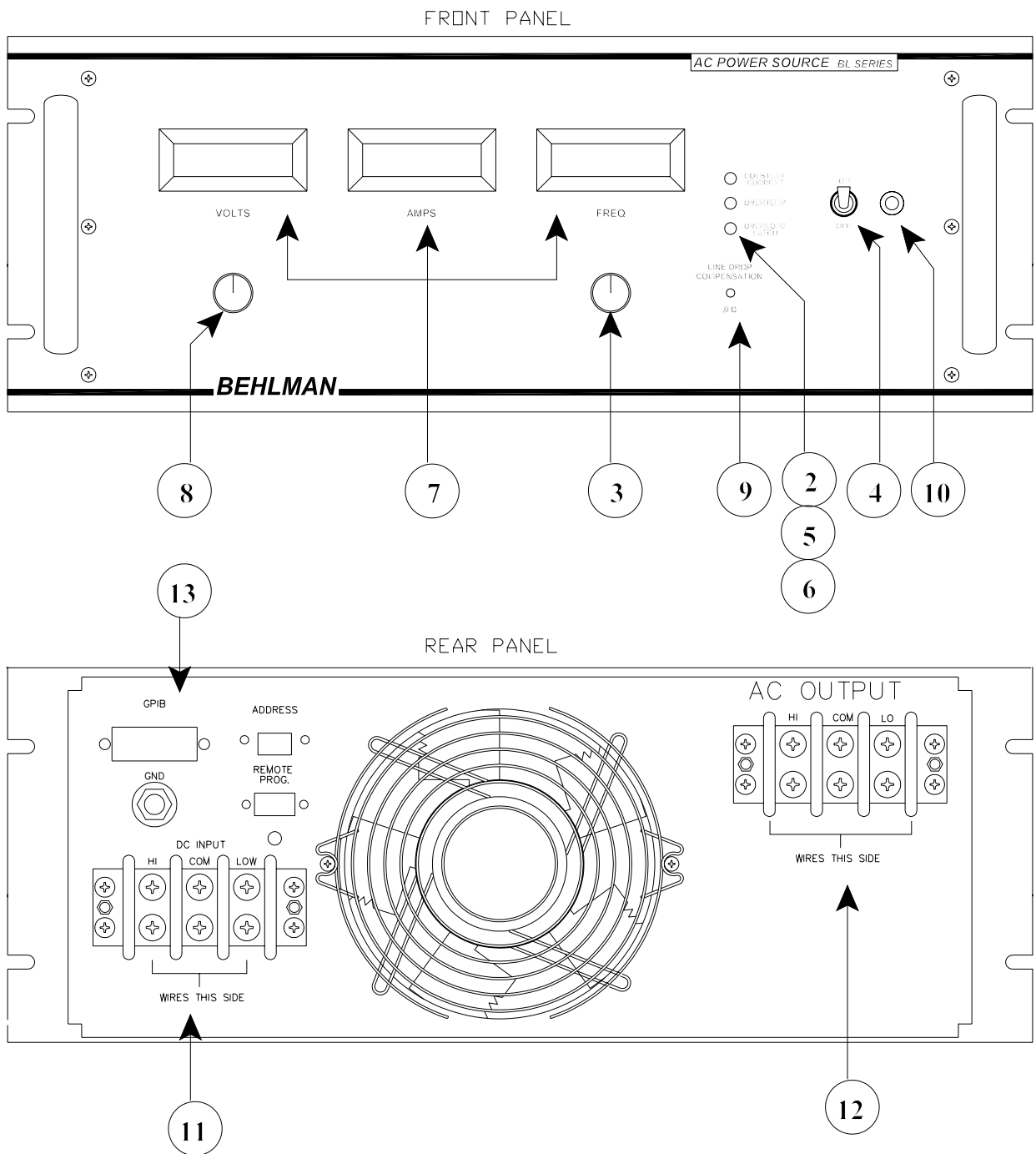

Figure 3 -1. BL6000 AC Source, Control Chassis Front and Rear Panel Views

### 3.5 REMOTE PROGRAMMING

#### 3.5.1 REMOTE PRGM CONNECTOR

The REMOTE PRGM connector, a nine-pin connector located on the rear panel, is provided to enable the user to program the unit remotely. A mating nine pin male connector is supplied to the user for fabricating the cable required for remotely setting the unit's amplitude, frequency, and on dual range models, the voltage range. It is recommended the user use AWG 20 wire to fabricate the cable. Table 3-2 lists the connector pin descriptions. During remote operation, the unit's front panel VOLTS and FREQ controls must be set fully ccw. A isolated 0 to 10 Vdc remote voltage is used to control the unit's output voltage from 0 to full-scale and its output frequency from 45 to 500 Hz.

#### 3.5.2 REMOTE AMPLITUDE AND FREQUENCY CONTROL

Two 0-10 Vdc control voltages from externally isolated voltage sources are used to control the unit's amplitude and frequency via the fabricated remote cable. Note the control inputs are tied to the power circuit common. This point is not the same as chassis potential unless externally connected ( see wiring info )

TABLE 3- 2. REMOTE PRGM CONNECTOR PIN DESCRIPTIONS

PIN	DESCRIPTION
1	External synch HI
2	External synch LO
3	Amplitude & frequency control (rtn).
4	Amplitude control (hi)
5	Frequency control (hi)
6	Output relay control
7	Output relay control
8	Range relay control
9	Range relay control

### 3.6 EXTERNAL SYNC

The unit provides for external synchronization via its rear panel REMOTE PRGM connector. When an external sync signal is applied to the unit, it reacts to produce an output frequency that is equal to the sync signal regardless of the FREQ control setting. The external sync can be either TTL compatible or an AC signal from 5 to 30 VRMS.

#### **CAUTION**

The external sync signal applied to the unit must not be lower than 45 Hz to avoid possible damage to the unit.

It is also recommended that load be de-energized and the output voltage of the power supply be set to zero before connecting a sync signal. This will prevent potentially damaging transients from reaching the load.

### 3.7 OPERATIONAL CONSIDERATIONS

#### GENERAL

All BL series incorporate an input rectifier system followed by a capacitive filter. To limit the in-rush current to the unit, a soft start circuit is employed. This circuit prevents nuisance tripping of protective circuits in the line circuits as well as reducing stress on internal components. When the unit is switched off for any reason a period of about 30 to 60 seconds is required to allow the soft start circuit to "reset". Failure to do so may cause the front panel breaker of the power supply to trip repeatedly as power is reapplied. This may lead to eventual failure of the breaker. In automated systems, a time delay relay should be considered to handle power interruptions.

#### OPERATION INTO LINEAR LOADS

The BL series will provide the best overall performance into a linear load. A linear load is characterized by that fact that its current wave shape is sinusoidal. The phase relationship between the voltage and current may be anything between 0 and 90 degrees (leading or lagging). Some examples of linear loads are as follows:

Most AC Motors	Power Transformers	Heating Elements
Resistors	Capacitors	Most Inductors
Incandescent Lighting ( without dimmers )		Most Solenoids

Operation into these types of loads usually cause little interaction with the output stage of the model BL6000. The main concern with a linear load is the "in-rush" current associated with it. Most heating elements and resistors have no in-rush concerns and usually do not present any problem for the power source. Inductive and capacitive loads may present a special problem based on their construction and the way in which they are energized. Motors and tungsten filament lamps also present some special "start-up" concerns. The following is intended to give the end user some insight into applying the AC source to these types of loads.

#### DRIVING REACTIVE LOADS

Capacitors and inductors are reactive in nature. If the load is applied during the peak of the AC cycle there may be a considerable in-rush of current several magnitudes larger than the steady state current. This current is only limited by any series resistance that may be present in the load circuit. Under the right conditions, this could trip the overload protection circuits in the power source. Certain transformers and solenoids (inductance) present the same problem.

Several methods can be used to prevent tripping the protection circuits in the power source. One common method is to insert a limiting impedance in series with the load. This could be in the form of a fixed resistor or NTC (Negative Temperature Coefficient) thermistor. Also, zero crossing switching can be employed. The most obvious way to prevent a high in-rush current is to apply the load with the voltage set to zero (or some low value) and energize the load slowly by turning up the voltage.

#### DRIVING LAMPS

Tungsten filament lamps, when cold, present a very low resistance. Once they are energized, their resistance quickly climbs to its steady state value. This characteristic must be accounted for when driving tungsten filament lamps. The same methods for driving reactive loads can be applied to tungsten.

### **3.6 OPERATIONAL CONSIDERATIONS (continued)**

#### **DRIVING MOTORS**

Driving an AC motor presents a special problem. Most motors require a starting current that is several times higher than the running current. This current may last for a few cycles to several seconds depending on the construction and mechanical load on the motor. This current is sometimes referred to as the motor's "locked rotor" current. This current is not to be confused with the inrush current that usually occurs over the course of one or two cycles of the AC waveform.

The BL series fold-back current limiting can be an advantage when starting motors. During the starting period, the motor will attempt to draw excessive power from the power source. The fold-back circuit will reduce the output voltage in order to maintain the maximum output current for the range in use. During this time the current supplied to the motor will remain sinusoidal, this allows the motor to start rotating. Once the motor reaches its normal operating speed, it generates the required "back EMF" and the supply current drops off to the nominal "run" current for the motor.

#### **DRIVING NON-LINEAR LOADS**

Loads utilizing rectifiers and SCRs interact with the AC power source and have a profound effect on the distortion of the output waveform. Consider the use of a bridge rectifier followed by a capacitive filter, the input current to this type of circuit is drawn in large "gulps" whenever the voltage across the capacitor falls below the peak of the input waveform. This current is limited only by the series impedance present in the wiring and capacitor. The impedance of large electrolytic capacitors is very small. This action causes a current waveform with a peak value that may be several times the RMS value. This ratio of peak current to RMS current is known as "Crest Factor". High values of crest factor cause distortion of the AC voltage waveform.

The amount of distortion incurred is dependant on many factors and is beyond the scope of this manual. It should be noted that this type of load may cause the output waveform to exhibit "flat topping". This should not be associated with a defect of the power source. Most "real world" electric distribution systems exhibit this distortion for this reason.

#### **OUTPUT NOISE**

Because the BL series uses a high frequency PWM conversion technique, a certain amount of output noise or ripple is to be expected. The amount of noise present on the output voltage waveform from this unit varies somewhat with the load. Maximum noise levels are present when there is no load applied. In any event, the amount of noise present should not constitute a problem for properly designed equipment. If the devices being tested are disabled by the noise present on the output waveform, then serious consideration should be given to the design of the unit being tested as it may not pass the European EMI tests.

In special cases where the output noise is objectionable, an external line filter can be added to the output of the unit. Please note that most line filters are not intended to be used at 400Hz. If the noise level is interfering with low level measurements a linear type AC source should be considered. For more information on linear sources, contact Behlman Sales.

#### **T6 & T6D UNITS**

Adding the external transformer chassis will affect the regulation specifications of the power supply when measured at the transformer secondary. This is due to the winding resistance of the transformer and will vary depending on which transformer is used. Higher voltage transformers tend to exaggerate this effect. An internal "boost" circuit has been added to the control chassis to minimize this drop in voltage versus load current. The boost circuit works very similar to the "Line Drop Compensation" provided on the control chassis ( see operating instructions).

## T6 & T6D UNITS ( continued )

For the reasons stated above, the output voltmeter accuracy and voltage regulation of these units will be degraded by this option. All specifications apply only when measured at the output terminals of the control chassis. If higher accuracy is required external metering should be considered.

It is recommended that the output be set to zero before switching ranges on T6D units. This will prevent nuisance tripping of protective circuits in the power chassis.

## UNITS WITH MT ( MOTOR TESTER ) OPTION

All BL series units provided with the MT option , require special operating considerations. These units are equipped with “ oversized” output devices to allow higher than rated output current for short periods of time. This is done to allow the starting of high inrush loads such as motors , contactors, and switching power supplies.

Current limiting in the BL is provided by two methods. Protection from a shorted output is provided by fast current limiting . This involves sensing of the output switching transistor’s saturation voltage and shutting down the drive circuit should this voltage exceed a safe value ( as under a shorted output ). This circuit responds within tens of microseconds. The current at which this occurs depends on many internal and external factors. Some of these are:

1. Resistance of short circuit
2. Inductance of output wiring
3. Frequency of output current
4. Size of output transistor ( smaller devices will trigger at lower currents )
5. Point in the AC waveform where the short occurs ( highest current at max peak)

A second current limit circuit responds to the long term ( a few hundred milliseconds ) current. When the preset current limit trip point is reached, the output voltage will decrease to maintain a constant current and sinusoidal output. This condition will exist until the overload is removed. This is a very useful feature for testing “Locked Rotor” motor current as well as other special loads.

Units with the MT option extend the amount of “fast” current limit by increasing the size of the output transistors utilized. This fact is transparent to the user and requires no special attention. The “slow” current limit circuit is modified to provide a higher trip value than standard units. This is done to keep the supply from jumping into the “constant current” mode during inrush testing. **IMPORTANT !! It is possible to overheat the output devices in an MT option unit if it is allowed to remain in current limit ( over 110 % rated ) for extended periods.** This unit has no means for limiting the amount of time it will operate in the constant current mode. If the equipment is to be left unattended, a method for limiting constant current operation should be provided. Typically the unit may be run in the constant current mode for several minutes with no ill effects. This time varies with the ambient temperature and duty cycle. Questions regarding MT units and safe operation in the constant current mode should be referred to the factory. All other BL series units may be run in the constant current mode indefinitely.

## SECTION 4

### MAINTENANCE AND ADJUSTMENTS

#### **WARNING**

This equipment involves the use of voltages and currents that can be hazardous. Only qualified personnel should be allowed to operate or service it. The top cover(s) must always be in place during operation.

Before performing any adjustments where access to the inside of the equipment is required, be sure to turn off the unit and allow five minutes for the DC power supply capacitors to discharge.

#### 4.1 MAINTENANCE

##### WARNING:

**FAILURE TO MAINTAIN OR OPERATE THE UNIT PROPERLY WILL VOID THE WARRANTY. AMONG THE ABUSES THAT ARE INCLUDED (BUT NOT LIMITED TO) ARE:**

**NOT MAINTAINING THE CLEANLINESS OF THE FILTERS (VACUUMING), OPERATING OUTSIDE THE ALLOWABLE ENVIRONMENT, AND PHYSICALLY DAMAGING THE UNIT.**

The decision on whether a units warranty is voided will be exclusively reserved for Behlman.

#### 4.2 ADJUSTMENTS

##### **NOTE**

All the potentiometers used in the procedures that follow are located on the control chassis. Always use a non-metallic screwdriver when adjusting potentiometers.

##### 4.2.1 TEST EQUIPMENT REQUIRED

TEST EQUIPMENT	MANUFACTURER/MODEL
Current Clamp	Fluke 80I-600 (or equivalent current transformer)
Digital Voltmeter (DVM)	Fluke 8062A (or equivalent)
Frequency Counter	HP 5314A (or equivalent)
Oscilloscope	Tektronix TDS series(or equivalent)

## 4.2.2 CONTROLLER CARD POTENTIOMETER ADJUSTMENTS

Since certain potentiometer adjustments affect other associated potentiometer settings, a sequence of adjustments must be followed to ensure the proper setting of each potentiometer within the three groups comprising the unit. The three groups: frequency, voltage, and current, are listed below in the sequence to be performed within each group.

<u>FREQUENCY</u>		<u>VOLTAGE</u>		<u>CURRENT</u>	
<u>POT.</u>	<u>PARA</u>	<u>POT.</u>	<u>PARA</u>	<u>POT.</u>	<u>PARA</u>
R15	4.2.3	R29	4.2.6	R34	4.2.9
R16	4.2.4	R61	4.2.7		4.2.10
R19	4.2.5	R58	4.2.8		

### 4.2.3 LOW FREQUENCY TRIM (45 Hz R15)

- 1) Connect frequency counter to rear panel output terminal strip.
- 2) Turn FREQ control fully ccw.
- 3) Set circuit breaker to ON.
- 4) Set OUTPUT switch to ON
- 5) Adjust VOLTS control until volts meter indicates 10 Vrms minimum.
- 6) Adjust 45 Hz potentiometer R15 until frequency counter indicates 45 Hz.

### 4.2.4 HIGH END FREQUENCY TRIM (500 Hz R16)

- 1) Turn FREQ control fully cw.
- 2) Adjust 500 Hz potentiometer R16 until frequency counter indicates 500 Hz.

### 4.2.5 FREQUENCY METER ADJUST (Hz-METER R19)

- 1) Turn FREQ control fully ccw.
- 2) Adjust Hz-METER potentiometer R19 until front panel meter indicates 500 Hz.

### 4.2.6 FULL SCALE OUTPUT VOLTAGE ADJUST (R29)

- 1) Using DVM set to ac volts, connect it across rear panel output terminal strip.
- 2) Turn VOLTS control fully ccw.
- 3) Set circuit breaker of power chassis to ON.
- 4) Set OUTPUT switch of power chassis to ON.
- 5) Adjust R29 until DVM indicates 270 VMS..



#### **4.2.7 VOLTAGE METER ADJUST (R61)**

- 1) Turn VOLTS control fully cw.
- 2) Adjust F.S. potentiometer R61 so that the front panel voltage meter indicates same as the DVM.

#### **4.2.8 CURRENT METER ADJUST (I-METER R58)**

- 1) Set circuit breaker to OFF.
- 2) Set OUTPUT switch to OFF.
- 3) Turn VOLTS control fully ccw.
- 4) Connect load to rear panel OUTPUT terminals.
- 5) Connect current clamp or other current measuring device to the load.
- 6) Set circuit breaker to ON.
- 7) Set OUTPUT switch to ON.
- 8) Adjust VOLTS control, making certain it does exceed 25 amps, to 270 VRMS. Increase load until current read on the measuring device is 20 amps ( or close).
- 10) Adjust I-METER potentiometer R58 on  $\phi$ A board until front panel current meter indication is the same as the load the current indicated by the external meter (step 9).

#### **4.2.9 20 KHz TRIANGLE WAVE TRIM (DIST. TRIM R34)**

- 1) Turn VOLTS control fully ccw.
- 2) Connect oscilloscope across rear panel output terminals.
- 3) Set oscilloscope gain to 500 mV/div.
- 4) Adjust DIST. TRM potentiometer R34 for smallest waveform peak-to-peak value.

#### **4.2.10 LINE DROP COMPENSATION TRIM**

- 1) Connect selected load to rear panel OUTPUT terminals.
- 2) Connect DVM at load input so as to compensate for IR losses in the connecting lines.
- 3) Set circuit breaker to ON.
- 4) Set OUTPUT switch to OFF.
- 5) Adjust VOLTS control to desired setting on DVM. Note voltage setting. (Should be the same as the panel meter indication.)
- 6) Set OUTPUT switch to ON.
- 7) Adjust front panel I.R. COMP potentiometer to pre-load voltage setting noted in step 5.

## SECTION 5

### THEORY OF OPERATION

#### 5.1 GENERAL

5.1.1 The BL series represents low cost, high performance, AC to AC power invertors. These units provide variable output voltage and frequency from 0 to 135 Vac and 45 to 500 Hz respectively. This series may be operated from a 120/208 Vac, 220/380 Vac 277/480 Vac, 200 Vac (Delta), or 346/600 Vac 2 phase or 120Vac or 240Vac single phase input line at 50 or 60 Hertz. Other versions include higher single phase outputs and external step-up/down output transformer options.

#### 5.2 INPUT POWER

5.2.1 The BL series models consist of two basic sections, and input power chassis (DC power supply) and an inverter/control chassis. The incoming line voltage is connected to the input chassis where it is applied to a multi-pulse transformer/rectifier system. The output of the rectifier circuit is applied to a large bank of electrolytic capacitors to provide the required filtering. The output of the power chassis is a bipolar DC voltage of +/-250 Vdc centered around the circuit common. Additional circuitry is incorporated to provide inrush current limiting and overload protection.

5.2.2 Inrush surge limiting is provided by placing large power resistors in series with two of the input phase voltages and the power chassis transformer primary. During power up, these resistors limit the current surge to the filter capacitor bank. Once full voltage is reached, a relay is used to bypass the limiting resistors allowing normal operation.

5.2.3 Over current protection of the DC supply is provided by the multi-pole input circuit breaker. Additional protection is provided by fast acting semiconductor fuses located in the control chassis.

5.2.4 The output of the power chassis is available at a rear panel mounted terminal block. Connection to the control chassis is afforded by supplied jumper cables. Note that the length of these cables is somewhat critical. Do not substitute with long cables.

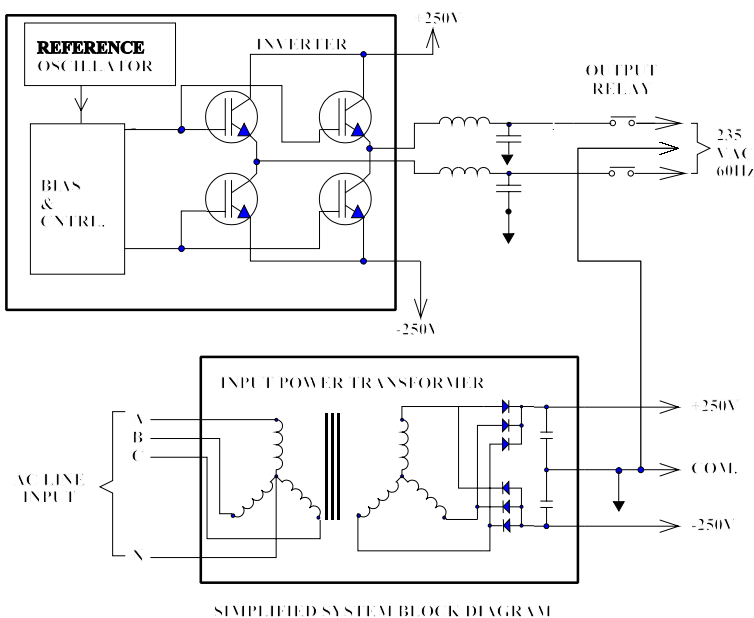

Figure 5.1, BL 6000 series block diagram

## 5.3 CONTROL CHASSIS

5.3.1 The control chassis contains the main power inverters, bias, and control circuitry. The diagram of Figure 1 depicts the basic functional blocks. Note that in the case of the three phase units, only one phase is illustrated as the others are identical. The circuitry is configured so that each of the three "Phase Control Cards" plug into a "Motherboard". The output devices and output filter components are mounted on separate assemblies.

5.3.2 Bias power for the control chassis is derived from the +250 Vdc rail. This voltage is applied to the Motherboard. All other operating voltages are provided by the Motherboard.

## 5.4 MOTHERBOARD

5.4.1 The Motherboard uses a fly-back type inverter to provide the following low voltage supplies.

- a. +/-15 Vdc for analog circuits
- b. +5 Vdc for metering circuits
- c. +12 Vdc for fans and relays
- d. isolated supplies for IGBT drivers

A quick indication of the supply status is provided by LEDS connected to each supply output.

5.4.2 The variable frequency 45 to 500 Hertz square-wave is generated on the Motherboard. A CMOS phase locked loop (U5), and 8 bit counter (U6) and Voltage Controlled Oscillator (U7) are the basis for the square-wave generator. The front panel frequency control sets a DC voltage which determines the frequency of the VCO. The VCO generates a square-wave at a frequency between 45 and 500 Hertz. This square-wave is used as a reference signal for the PLL. The frequency of the VCO is multiplied by a factor of 256 by the PLL. The resultant is used as a clock signal for the 8 bit counter.

5.4.3 In order to produce data in the form of a sine-wave, a "Look-up" table is stored in a PROM on each phase control card. The outputs of the 8 bit counter are tied to the address lines of each PROM. As the clock runs, the data in the PROMS are clocked into the D/A convertors. This action produces a series of steps at the output of the D/A convertor that approximate a sine-wave. Further filtering produces a clean sine-wave at the frequency of the VCO. Phase displacement is determined by the PROM data.

5.4.4 The mother board also produces a triangle-wave signal that is common to the PWM modulators contained on the phase control cards discussed later.

5.4.5 All inter-connection between circuits and controls are provided via the Motherboard. Four 22 pin card edge connectors are present for the installation of 3 phase control cards and a GPIB interface card. Distribution of all low voltage supplies is via the Motherboard.

## 5.5 OUTPUT INVERTER

5.5.1 The 2 output inverters are based on a half bridge topology. A 600 volt, 100 amp, IGBT module is connected between the +/-250 Vdc rails. The drive signal to the inverter is a "sine weighted" Pulse Width Modulated (PWM), isolated rectangular pulse train. The output of the half bridge is a 20 Khz pulse train that swings 500 volts peak-to-peak and has a varying duty cycle based on the modulating signal (sine-wave generator). This output is filtered by a low pass network. The result is a sine-wave voltage that is an amplified version of the sine-wave signal.

5.5.2 Pulse Width Modulation is performed by the individual phase control cards. The tri-wave signal generated by the Motherboard is distributed to each phase control card. Components U7, U12, U13, and U14 form a modulator circuit that provides a dual polarity PWM signal that is applied to optically-coupled driver IC's U17 and U18. These driver IC's provide boosted, isolated, drive for the upper and lower IGBT of the output inverter. The two inputs to the modulator are the 20 KHz tri-wave and the locally generated sine-wave.

5.5.3 The driver IC's provide short circuit protection via an isolated fault output. This circuit detects the VCE voltage of the upper and lower IGBT. If the output of the inverter is shorted the IGBT's collector to the emitter voltage will increase and trigger the short circuit detection. The fault detect signal is used to set a latching lock out that turns off the PWM drive signals. The latch logic is comprised of U9, U10, U12 on the Motherboard. The latch must be reset by cycling power.

## Theory of operation (continued)

5.5.4 The output amplitude of each phase is also regulated by the phase control card. A sample of the output voltage is fed to an RMS to DC converter (U4). The resultant DC voltage is compared to a reference DC voltage set by the front panel voltage control or remote interface. This comparison is performed by U3a and is integrated to provide an error signal to control the amplitude of the sine-wave signal fed to the PWM modulator. Compensation for load line (wire) drops performed by summing in a signal from the current monitor. The more current control drawn, the more correction is provided. This compensation is adjustable via the front panel.

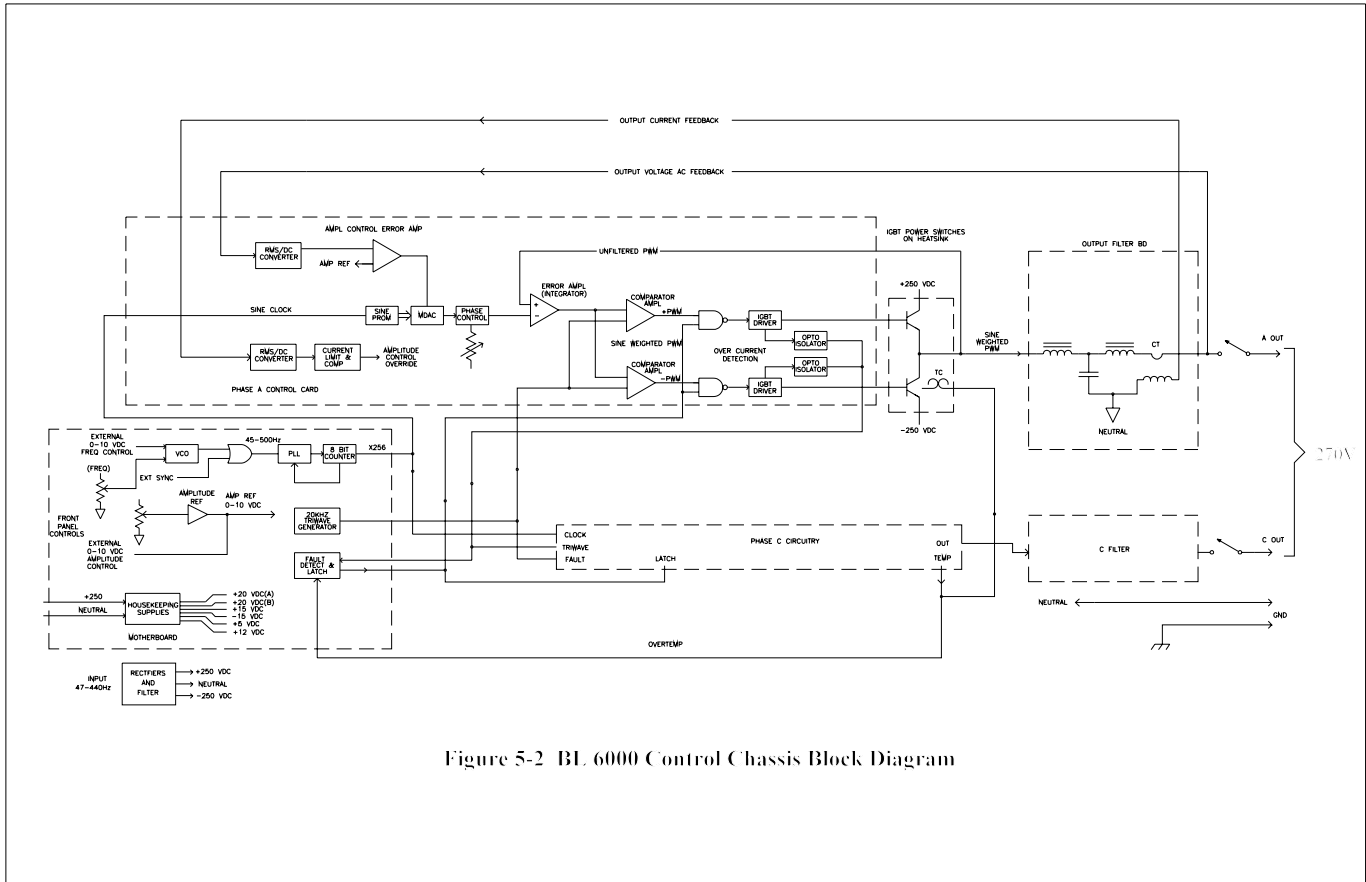

Figure 5-2 BL 6000 Control Chassis Block Diagram

## 5.6 METERING

5.6.1 Metering is provided by DC signals taken from the phase control cards. These signals are derived from the voltage and current monitoring circuits. These signals are attenuated and applied to the front panel DVM's. The frequency display derives its data from the VCO signal.

## 5.7 MISCELLANEOUS

5.7.1 Internal heat-sink temperature is monitored via a sensor mounted to the extrusion. The sensor is normally open but will close when a safe temperature is exceeded. When this sensor closes the PWM signal is eliminated by setting the same latch used by the short circuit protection.

5.7.2 The optional GPIB board provides an isolated computer interface for remote control of frequency, voltage, and the output relay. The GPIB card will also provide read-back of current and voltage to the GPIB.

## 5.8 THEORY OF OPERATION FOR GPIB \ RS232 INTERFACE

All BL series power supplies including the "I" option contain an additional circuit card providing a computer interface. This interface may be one of two standards, IEEE 488 or RS232. This card controls the supply output voltage, frequency, and range as well as providing data back to the controlling computer. Operation of the interface card is described in the following section. See figure 5-2 below.

The heart of the interface card is the 80C196 micro processor U17. This device used in conjunction with a programmable memory/logic device U18, provides all the required communication functions. RS232 communications are handled directly by U17 while IEEE 488 protocol is handled by buss controller U19. U19 is an industry standard TMS 9914. Data stored in the U18 EEPROM determines which communication proto call is selected. EEPROM data also determines scale factor and other set up parameters which are determined by the actual model and size of the unit being controlled.

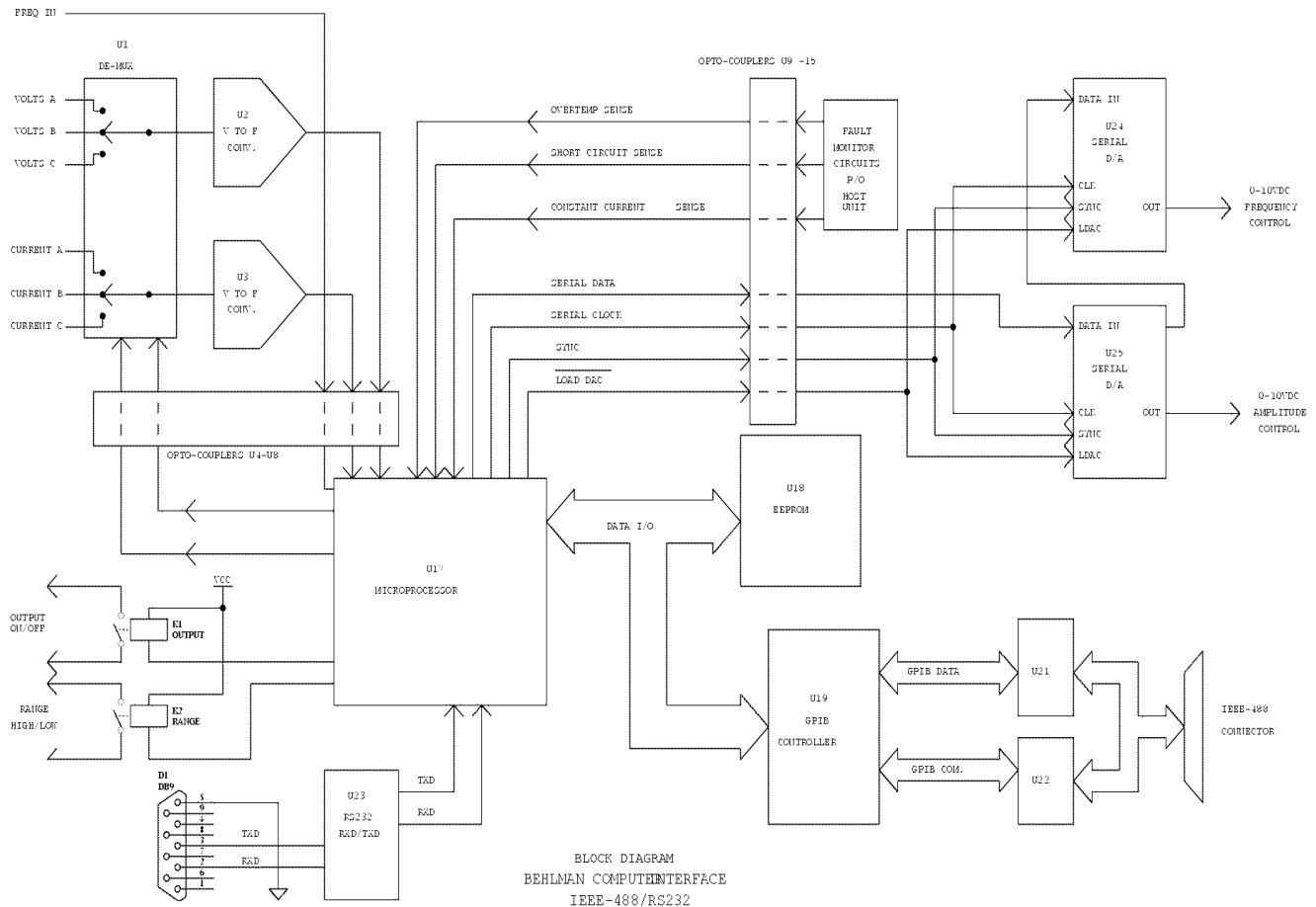

Figure 5-2

Programmed output voltage and frequency data is applied to serial D/A converters. These converters provide a 0 to 10Vdc output that is applied to the analog remote inputs of the host unit. Control of these parameters is as described in the theory of operation for the power source.

Read back of output current and voltage is obtained by monitoring the internal circuits of the power source. These dc signals are selected via U1 a two channel "one of four" de-multiplexer. Note that the actual number of channels and inputs used depends on the model of the power source. Again, this is determined by the

EEPROM data . The outputs of U1 are applied to a set of voltage to frequency convertors. The output of these convertors range from 100 Hertz to 200 Hertz. These frequencies are measured by the microprocessor and

scaled to provide the proper current and voltage data to the controlling computer. The output frequency of the power supply is measured by monitoring its internal clock signal via U4. This input is labeled "Hz-FDBK".

Control of the output on/off relay and range relay is provided via the interface board via dry contacts from K1 and K2. These small PCB mounted relays are controlled by U18. All signals coming to and exiting from the interface board and the power source are optically isolated. This adds a measure of safety and prevents ground loops between the controlling computer and power source circuitry.

All firmware for the interface card is written in INTEL's PL/M format. A list of supported commands and syntax is provide in appendix B and C of this manual.

## APPENDIX A

### IGBT DRIVER

The insulated gate bipolar transistor (IGBT) driver is a hybrid IC that is used in the over-current detector circuit of each BL6000 unit. Two of these drivers are used in each unit to provide signal isolation, over-current detection, and low-speed over-current cutoff features. Figure 1 shows the internal parts of an IGBT driver and its pin descriptions.

**SIGNAL ISOLATION** - A photo-coupler with a high isolation voltage is used for signal isolation.

**OVER-CURRENT DETECTION** - The IGBT driver can withstand an over-current of 10  $\mu$ sec duration when short circuited. An extremely fast protection circuit is used here for this reason.

**LOW-SPEED OVER-CURRENT CUTOFF** - A low-speed cutoff circuit slowly turns off the IGBT driver in response to an over-current sensing. This feature protects the IGBT against damage from high voltage spikes generated during normal drive speed cutoffs.

PIN	DESCRIPTION
1	Connected to smoothing capacitor for reverse bias power supply.
2	Power supply (+20 Vdc).
3	Drive output.
4	Not connected.
5	Over-current detection output.
6	Collector voltage monitoring.
7,8	Not connected.
9	Power supply (0 Vdc).
10-13	Not connected.
14	Drive signal input (-).
15	Drive signal input (+).

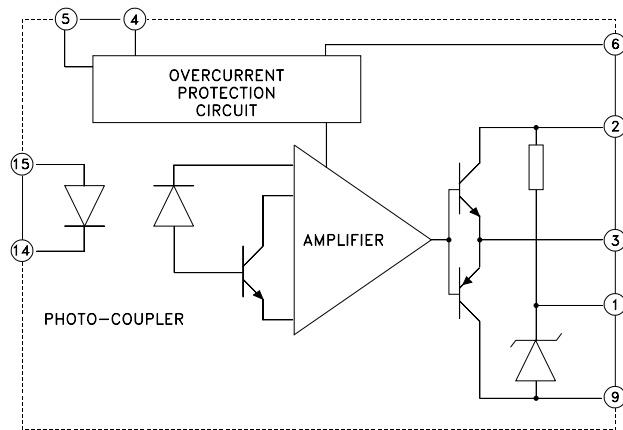

Figure 1. IGBT Driver, Pin Description and Schematic

## APPENDIX B

### BL SERIES AC POWER SUPPLY IEEE-488 INTERFACE SPECIFICATIONS

#### 1.1 IEEE-488 BUS UTILIZATION

The BL Series Power Supplies incorporates an embedded TMA that is compatible with the electrical and mechanical standards outlined in IEEE-STD-488. The IEEE-488 interface uses a TI LSI device to implement all necessary talker/listener functions. This device is configured under software control to support the following subsets:

- SH1 - Source Handshake
- AH1 - Acceptor Handshake
- T8 - Basic Talker
- L4 - Basic Listener
- DC1 - Device Clear
- RL0 - No Remote / Local Function
- SR0 - No Service Request
- PP0 - No Parallel poll response
- DT0 - No Device Trigger
- C0 - Not a controller

#### 1.2 IEEE-488 BUS COMMANDS

##### 1. Single-Line Commands

IFC - Clears GPIB interface

##### 2. Multi-Line Command

DCL - Resets AC Power Supply to the quiescent state if a catastrophic failure is not present. The only way to clear a catastrophic failure is to read the Power Supply's response by using the Status command.

#### 1.3 GPIB COMMUNICATION

The embedded TMA receives ASCII encoded command strings via a GPIB IEEE-488 according to MATE System Control Interface Standard No. 2806763 (IEEE-716 CIIL). Programmed I/O is utilized to transmit and receive command strings after a talker/listener relationship is established. The AC Power Supply supports all OPCODES, NOUNS, and MODIFIERS required by the stimulus module. They are as follows:

##### OPCODES

FNC, FTH, INX, :CH0, SET, SRX, SRN, CLS, OPN, RST, CNF, IST,  
STA

##### MODIFIERS

FREQ, VOLT, CURR, VLT0, VLT1

##### NOUN

ACS

1.4



## AC POWER SUPPLY SYNTAX

Setup Command:

**FNC ACS :CH0 SET VOLT <value>**

[ **SET FREQ** <value>]  
[ **SRX VOLT** <value>]  
[ **SRN VOLT** <value>]  
[ **SRX FREQ** <value>]  
[ **SRN FREQ** <value>]  
[**SET VLT(0,1)**] <cr><lf>

- All **SET**, **SRX**, **SRN** commands are part of the setup command above.

Table 1-1

### CIIL SOFTWARE COMMANDS

#### CIIL COMMANDS

#### EXPLANATION

#### **SET VOLT** <value>

Sets output voltage to given value, in volts rms. The following values are permitted:

$0 \leq \text{value} \leq 135$ , or  $270$ , dependent on range selected and type of unit.

If set volt (value) not received, then use **SRN VOLT** (value), or **SRX VOLT** (value). If none of these 3 are sent then generate error message.

#### **SET FREQ** <value>

Optional. Sets frequency of output voltage to given value, in Hz. The following values are permitted:

$45 \leq \text{value} \leq 500$ .

Default is 60 Hz only if **SET FREQ**, **SRN FREQ**, or **SRX FREQ** are not received. Otherwise the values shall be used in the order stated.

#### **SRX VOLT** <value>

Optional. Sets maximum limit for **SET VOLT** command. If **SET VOLT** value is greater than **SRX VOLT** value in a command string, an error message is generated and the setup command ignored. The following values are permitted:

$0 < \text{value} \leq 34$ , or  $135$ , or  $270$ , dependent on range selected and type of unit.

If a value for **SRX VOLT** is not specified, the required maximum value for **SET VOLT** default to 34, or 135, or 270, dependant on range selected and type of unit.

Table 1-1  
 CIIL SOFTWARE COMMANDS (cont)

<u>CIIL COMMANDS</u>	<u>EXPLANATION</u>
<b>SRN VOLT</b> <value>	<p>Optional. Sets minimum value limit for <b>SET VOLT</b> command. If <b>SET VOLT</b> value is less than <b>SRN VOLT</b> value in a command string, an error message is generated and a setup command ignored. The following values are permitted:</p> <p><math>0 \leq \text{value} &lt; 135</math>, or <math>270</math>, dependent on range selected and type of unit.</p> <p>The SET VOLT default is 0 for the minimum value if a value is not specified for SRN VOLT.</p>
<b>SRX FREQ</b> <value>	<p>Optional. Sets maximum limit for <b>SET FREQ</b> command. If the <b>SET FREQ</b> value in a command string is greater than the maximum limit, an error message is generated and the setup command ignored. Legal values are:</p> <p><math>45 &lt; \text{value} \leq 500</math>.</p> <p>If a value for SRX FREQ is not specified, <b>SRX FREQ</b> defaults to 500.</p>
<b>SRN FREQ</b> <value>	<p>Optional. Assigns minimum value to <b>SET FREQ</b> command. If the <b>SET FREQ</b> value in a command string is less than the minimum limit, an error message is generated and the setup command ignored. Legal values are:</p> <p><math>45 \leq \text{value} &lt; 500</math>.</p> <p>If a value for <b>SRN FREQ</b> is not specified, <b>SRN FREQ</b> defaults to 45.</p>
<b>SET VLT0</b>	Set LO voltage range.
<b>SET VLT1</b>	Set HI voltage range.

Delay is necessary after issuing setup command, due to output voltage slew rate of 100v per 250 ms.

On dual range Power Supplies, this command selects the LO or HI voltage range. Dual Ranges are 0-135 volts and 0-135/0-270 volt. If this command is omitted from the setup string the unit will default to the lowest available range. On single range units this command will be ignored.

NOTE

1. The setup command specifies the voltage and frequency of the AC power Supply output. The AC Power Supply responds only to the last setup command entry. Its memory does not retain previously entered setup commands.
2. During IEEE operation, the unit's front panel VOLTS and FREQ controls must be fully CCW. If the controls are not set fully CCW, then the output voltage and frequency will be a sum of the programmed value and the value set with the front controls. The front panel OUTPUT switch must be set to OFF position. The front panel RANGE switch (on dual range units) must be set to LO.

Table 1-1  
CILL SOFTWARE COMMANDS (cont)

<u>CILL COMMANDS</u>	<u>EXPLANATION</u>
<b>FTH VOLT</b> <cr><lf>	The AC supply responds to this command by transmitting the RMS voltage (in volts resolute to 0.1V) measured at its output, in decimal format as follows: <sp><digit><digit><digit><dp><digit><cr><lf>
<b>FTH CURR</b> <cr><lf>	The AC Supply responds by transmitting the current (in amps resolute to 0.1A) measured at its output, in decimal format, as follows: <sp><digit><digit><dp><digit><cr><lf>
<b>FTH FREQ</b> <cr><lf>	The AC Supply response by transmitting the frequency (in hertz) measured at its output, in decimal format, as follows: <sp><digit><digit><digit><cr><lf>
<b>CLS :CH0</b> <cr><lf>	Closes output relay contacts. Connects AC Power Supply outputs to output terminal block. The setup command specifies the voltage and frequency. The setup command must be entered before the <b>CLS :CH0</b> command.
<b>OPN :CH0</b> <cr><lf>	Opens output relay contacts. Disconnects output of AC Power Supply from output connector. AC Power Supply retains voltage and frequency assigned by setup command.
<b>RST ACS :CH0</b>	Resets AC Power Supply to quiescent. The output relay opens and error messages are erased.  Catastrophic error messages are cleared by reading the Power Supply's response, by use of the Status command.
<b>CNF</b> <cr><lf>	Instructs AC Power Supply to perform internal confidence test. STA command transmits the message. The AC Power Supply responds with one of the following:  <u>Pass</u> <sp><cr><lf>  <u>Fail</u> F07ACS0(DEV): CONFIDENCE TEST FAILURE <cr><lf>

Table 1-1  
CILL SOFTWARE COMMANDS (cont)

**IST** <cr><lf>

Instructs AC Power Supply to perform internal self test. The **STA** command transmits the message. The AC Power Supply responds with one of the following:

Pass  
<sp><cr><lf>

Fail  
F07ACS0(DEV): BIT TEST FAILURE  
-PROM CHECKSUM FAULT  
-RAM FAULT  
-AC SUPPLY HARD FAULT  
<cr><lf>

CILL COMMANDS

EXPLANATION

**STA** <cr><lf>

Status. Prepares AC Power Supply for a response transmission. Clears error condition if one exists. The following response messages and conditions exclude confidence and internal self  
<sp><cr><lf>

Device error messages

F07ACS0(DEV):BIT TEST FAILURE  
<description consisting of up to 60 characters>< cr><lf>

TMA error messages All begin with:  
F07ACS0 (MOD):

This message is followed by one explanatory message from the following text:

ILLEGAL NOUN  
AC Power Supply does not recognize illegal noun.

ILLEGAL NOUN MODIFIER  
AC Power Supply does not recognize illegal noun modifier.

ILLEGAL OPCODE  
AC Power Supply does not recognize illegal opcode.

ILLEGAL VALUE  
Entered value lies outside upper and lower limits.

NO SETUP  
Close command received but setup not programmed.

Example: F07ACS00(MOD): NO SETUP <cr><lf>

## 1.5 CATASTROPHIC ERRORS

A catastrophic failure is generated each time the AC Power Supply experiences a hardware failure. Errors are cleared whenever the AC Power Supply transmits a response, except in the case of a short circuit fault which may only be cleared by cycling power to the AC Supply.

### Catastrophic Error Messages

All begin with:

F00ACS0(DEV):

This message is followed by one explanatory message from the following text:

OVERTEMP FAULT <cr><lf>

The heat-sink temperature has exceeded its upper limit. The OVERTEMP LED on the front panel will light.

CURRENT LIMIT FAULT <cr><lf>

SHORT CIRCUIT FAULT: AC SUPPLY <cr><lf>

An output loading fault has occurred causing the supply to exceed 500% rated current output. The supply automatically shuts down and opens its output relay. The OVERLOAD LATCH LED on the front panel will light.

## 1.6 ADDRESS SELECTION

The GPIB Address for the BL Series Power Supplies is configured via the dip-switch located on the rear panel. The dip-switch represents the address in binary format. Valid GPIB Address settings are from 0 to 30. Switch 1 is the LSB, switch 5 is the MSB. Each individual switch bit is set ('1') when in the 'OFF' position and reset ('0') when in the 'ON' position.

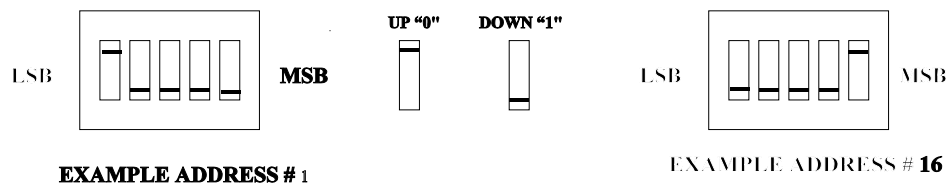

## 1.7 THREE PHASE COMMUNICATION

The GPIB Interface of the BL has additional Fetch commands which allows the user to Fetch voltage and current from each phase. If no phase is specified during a Fetch for current or voltage, then the response is an average of the three phases.

### FETCH DATA COMMANDS FOR THREE PHASE UNITS

<b>FTH VOLT</b> <1, 2, or 3><cr><lf>	The AC Supply response to this command by transmitting the RMS voltage (in volts) for the individual phase specified, measured at its output.
<b>FTH VOLT</b> <cr><lf>	The AC Supply responds by transmitting the average RMS voltage for the 3 phases.
<b>FTH CURR</b> <1, 2 or 3><cr><lf>	The AC Supply responds by transmitting the average current (in amps) for the individual phase specified, measured at its output.
<b>FTH CURR</b> <cr><lf>	The AC Supply responds by transmitting the average current for the 3 phases.

All other commands for Fetch remain the same as BL, described on page B-4 of this appendix.

The setup commands for the three phase units remain the same. The operation of the BL prohibit adjusting voltages for phases individually, therefore phase cannot be specified during the "SET VOLT" command.

### **GPIB PROGRAMMING EXAMPLE FOR THREE PHASE UNIT**

Examples of actual command strings transmissions and typical responses are outlined below.

All commands must be in upper case ASCII, lower case characters are ignored. All commands transmitted to the BL must terminate with a carriage return <cr> and a line feed <lf>, as will all responses received from the BL.

**IMPORTANT NOTE:** The EOI line of the GPIB controls **MUST** be asserted when transmitting the line feed character, otherwise the BL Source will not recognize command reception and command processing will not occur.

1. **EXAMPLE:** Setup a single range BL Source to output 120 V @60Hz, and close the output relay.

Transmit setup command:

**FNC ACS :CH0 SET VOLT 120 SET FREQ 60** <cr><lf>

Transmit status command to request status response:

**STA** <cr><lf>

Talk address the BL Source to enable response:

<space><cr><lf>:Positive response indicating status is OK.

F07ACs00 (MOD) ILLEGAL VALUE <cr><lf>: Negative response indicating error condition.

(Typically a negative response would only occur if an error existed in the entry or reception of the command string, or the values entered were out of range of the BL Source),

Transmit output relay close command:

**CLS :CH0** <cr><lf>

Transmit status command to request status response:

**STA** <cr><lf>

Talk address the BL Source to enable response:

<space><cr><lf>:Positive response indicating status is OK.

F07AC500(MOD) NO SETUP <cr><lf>:Negative response indicating error condition.

(Negative response would only occur if invalid or no setup string had been transmitted prior to close command).

2. EXAMPLE: Setup a dual range BL Source to output 30 V @400 Hz.

Transmit setup command to request status response:

**FNC ACS :CH0 SET VOLT 30 SET FREQ 400 Hz.**

Transmit status command to request status response:

**STA <cr><lf>**

Talk address the BL Source to enable response:

<space><cr><lf>:Positive response indicating status is OK.

3. EXAMPLE: Setup a dual range BL Source to output 115 V on high range @50Hz, and read back what the actual voltage, current and frequency being output is set at.

Transmit setup command

**FNC ACS :CH0 SET VOLT 115 SET FREQ 50 SET BLT1 <cr><lf>**

Transmit status command to request status response:

**STA <cr><lf>**

Talk address the BL Source to enable response:

<space><cr><lf>:Positive response indicating status is OK.

Transmit output relay close command:

**CLS :CH0 <cr><lf>**

Transmit status command to request status response:

**STA <cr><lf>**

Talk address the BL Source to enable response:

<space><cr><lf>:Positive response indicating status is OK.

Transmit fetch volt command:

**FTH VOLT <cr><lf>**

Talk address the BL Source to enable response:

115.0 <cr><lf>

Transmit fetch current command:

**FTH CURR <cr><lf>**

Talk address the BL Source to enable response:

5.2 <cr><lf>

Transmit fetch frequency command:

**FTH FREQ <cr><lf>**

Talk address the BL Source to enable response:

50.0 <cr><lf>

## GPIB PROGRAMMING EXAMPLE FOR THREE PHASE UNIT

**1. EXAMPLE:** Setup single range BL to output 120 V @ 60 Hz and read back actual voltage and current from phase 2 and the average voltage. Assume for this example a load is connected drawing 1.5 amps RMS from phases 1 and 2, 0 amps from phase 3.

Transmit setup command:

**FNC ACS: CH0 SET VOLT 120 SET FREQ 60** <cr><lf>

Transmit status command to request status response:

**STA** <cr><lf>

Talk address the BL source to enable response:

<space><cr><lf>:Positive response indicating status is OK.

Transmit output relay close command:

**CLS :CH0** <cr><lf>

Transmit status command to request status response:

**STA** <cr><lf>

Talk address the BL source to enable response:

<space><cr><lf>:Positive response indicating status is OK.

Transmit fetch volt command for phase 2:

**FTH VOLT2** <cr><lf>

Talk address the bl source to enable response:

120.0 <cr><lf>

Transmit fetch volt command for average of 3 phases:

**FTH VOLT** <cr><lf>

Talk address the BL source to enable response:

120.0 <cr><lf>

Transmit fetch current command for phase 2:

**FTH CURR2** <cr><lf>

Talk address the BL source to enable response:

1.5 <cr><lf>

Transmit FTH current command for average of 3 phases:

**FTH CURR** <cr><lf>

Talk address the BL source to enable response:

1.0 <cr><lf>:Average of 3 phases.



## APPENDIX C

### BLSERIES AC POWER SUPPLY EIA-232 SERIAL INTERFACE SPECIFICATIONS

#### 1.0 INTRODUCTION

The RS232 interface option for the BL series AC Power Supplies allows two way communication with most computer systems. All programmable setup parameters may be queried or modified via the RS232 interface using command syntax described below.

#### 1.1 EIA-232 INTERFACE UTILIZATION

The RS232 interface may be connected to modems, controllers, computers, or any other equipment capable of communicating with the RS232 protocol. It is assumed in the remainder of this document that the RS232 interface is connected to a "host" computer.

The interface is configured to communicate with the following format:

Duplex:	Full
Baud Rate:	9600
Bits:	8
Parity:	None
# Stop Bits	1

Other BAUD rates, however, are available by special order

#### 1.2 EIA-232 CONNECTIONS

##### SIGNAL

	<u>AC SOURCE</u> (DB-9)	<u>HOST</u> (ANY)
GND	5 -----	GND
RXD	2 -----	TXD
TXD	3 -----	RXD

The RS232 interface does not currently support hardware handshaking.

Use of a good quality shielded cable is recommended. All cables should be secured with proper retaining hardware .

#### **Important !**

**When using remote control, all control chassis front panel controls must be set fully counter-clock wise. The output switch and range switch (optional) must be set to the "off" position ( low for range switch). Failure to do so will prevent proper control.**

### 1.3 EIA-232 SERIAL COMMUNICATION

The BL Series Power Supply incorporates an EIA-232 serial communications interface, which allows all function to be programmed and monitored remotely via a host computer.

The Power Supply receives ASCII encoded command strings via a EIA-232 interface according to MATE System Control Interface Standard No. 2806763 (IEEE-716 CIIL). The AC Power Supply supports all OPCODES, NOUNS, and MODIFIERS required by the stimulus module. They are as follows:

#### OPCODES

FNC, FTH, :CHO, SET, SRX, SRN, CLS, OPN, RST, CNF, IST, STA INX,

#### MODIFIERS

FREQ, VOLT, CURR, VLT0, VLT1

#### NOUN

ACS

The BL Series Power Supply can be used in point-to-point mode where a host Computer is connected directly to One Power Supply.

#### **NOTES:**

1. Leading zeroes must be entered for commands.
2. Leading zeroes are blanked in response transmit.

#### **EXAMPLES:**

### 1.4 AC POWER SUPPLY SYNTAX

Setup Command:

FNC ACS :CHO SET VOLT <value>

```
[ SET FREQ <value>]
[ SRX VOLT <value>]
[ SRN VOLT <value>]
[ SRX FREQ <value>]
[ SRN FREQ <value>]
[SET VLT(0,1)] <cr><lf><eos>
```

Table 1-1

#### **CIIL SOFTWARE COMMANDS**

(cr) =ASCII ' carriage return' code 0D Hex, ISO keyboard ^M  
(lf) =ASCII ' line feed ' code 0A Hex, ISO keyboard ^J  
(eos) =ASCII 'carriage return' code 1A Hex, ISO keyboard ^Z  
ASCII file transfer end-of string command

## CIIL COMMANDS

## EXPLANATION

**-ALL SET, SRX,SRN**

commands are part of the setup command above.

**SET VOLT <value>**

Sets output voltage to given value, in volts rms. The following values are permitted:

$0 \leq \text{value} \leq 135$ , or 270, dependent on range selected and type of unit.

If set volt (value) not received, then use **SRN VOLT** (value), or **SRX VOLT** (value). If none of these 3 are sent then generate error message.

**SET FREQ <value>**

Optional. Sets frequency of output voltage to given value, in Hz. The following values are permitted:  $45 \leq \text{value} \leq 500$ . Default is 45 Hz only if **SET FREQ**, **SRN FREQ**, or **SRX FREQ** are not received. Otherwise the values shall be used in the order stated.

**SRX VOLT <value>**

Optional. Sets maximum limit for **SET VOLT** command. If **SET VOLT** value is greater than **SRX VOLT** value in a command string, an error message is generated and the setup command ignored. The following values are permitted:

$0 < \text{value} \leq 135$ , or 270, dependent on range selected and type of unit.

If a value for **SRX VOLT** is not specified, the required maximum value for **SET VOLT** default to 135, or 270, dependant on range selected and type of unit.

**SRN VOLT <value>**

Optional. Sets minimum value limit for **SET VOLT** command. If **SET VOLT** value is less than **SRN VOLT** value in a command string, an error message is generated and a setup command ignored. The following values are permitted:

$0 < \text{value} < 135$ , or 270, dependent on range selected and type of unit.

The **SET VOLT** default is 0 for the minimum value if a value is not specified for **SRN VOLT**.

**SRX FREQ <value>**

Optional. Sets maximum limit for **SET FREQ** command. If the **SET FREQ** value in a command string is grater than the maximum limit, an error message is generated and the setup command ignored. Legal values are:

$45 < \text{value} < 500$ .

If a value for **SRX FREQ** is not specified, **SRX FREQ** defaults to 500.

**SRN FREQ <value>**

Optional. Assigns minimum value to **SET FREQ** command. If the **SET FREQ** value in a command string is less than the minimum limit, an error message is generated and the setup command ignored. Legal values are:

$45 \leq \text{value} < 500$ .

If a value for **SRN FREQ** is not specified, **SRN FREQ** defaults to 45.

**SET VLT0**  
**SET VLT1**

Set LO voltage range.  
Set HI voltage range.

## Notes

Delay is necessary after issuing a setup command, due to the output voltage slew of 100v per 500ms.

On dual range Power Supplies, this command selects the LO or HI voltage range. Dual Ranges are 0-135 volts and 0-135/0-270 volt. If this command is omitted from the setup string the unit will default to the lowest available range. On single range units this command will be ignored.

### NOTES:

1. The setup command specifies the voltage and frequency of the AC power Supply output. The AC Power Supply responds only to the last setup command entry. Its memory does not retain previously entered setup commands.

2. During EIA-232 remote operation, the unit's front panel VOLTS and FREQ must be fully CCW. If the controls are not set fully CCW, then the output voltage and frequency will be a sum of the programmed value and the value set with the front controls. Front Panel OUTPUT switch must be set to OFF position. Front Panel RANGE switch must be set to LO.

## CILL SOFTWARE COMMANDS (cont)

### CILL COMMANDS

### EXPLANATION

#### FETCH DATA COMMAND:

**FTH VOLT** <cr><lf><eos>

The AC supply responds to this command by transmitting the RMS voltage (in volts) measured at its output, in decimal format as follows:  
<sp><digit><digit><digit><dp><digit><digit><cr><lf><eos>

**FTH CURR** <cr><lf><eos>

The AC Supply responds by transmitting the current (in amps) measured at its output, in decimal format, as follows:

<sp><digit><digit><dp><digit><cr><lf><eos>

**FTH FREQ** <cr><lf><eos>

The AC Supply response by transmitting the frequency (in hertz) measured at its output, in decimal format, as follows:

<sp><digit><digit><digit><cr><lf><eos>

**CLS :CH0** <cr><lf><eos>

Closes output relay contacts. Connects AC Power Supply outputs to output terminal block. The setup command specifies the voltage and frequency. The setup-command must be entered before the **CLS :CH0** command.

**OPN :CH0** <cr><lf><eos>

Opens output relay contacts. Disconnects output of AC Power Supply from output connector. Ac Power Supply retains voltage and frequency assigned by setup command.

**RST ACS:CH0**

Resets AC Power Supply to quiescent. The output relay opens and error messages are erased.

Catastrophic error messages are cleared by reading the Power Supply's response, by use of the Status command.

**CNF** <cr><lf><eos>

Instructs AC Power Supply to perform internal confidence test. **STA** command transmits the message. The AC Power Supply responds with one of the following:

Pass  
<sp><cr><lf><eos>

CILL SOFTWARE COMMANDS (cont)

CILL COMMANDS

EXPLANATION

	<u>Fail</u> F07ACSO(DEV): CONFIDENCE TEST FAILURE <cr><lf><eos>
<b>IST</b> <cr><lf><eos>	Instructs AC Power Supply to perform internal self test. The STA command transmits the message. The AC Power Supply responds with one of the following:  <u>Pass</u> <sp><cr><lf><eos>
	<u>Fail</u> F07ACSO(DEV): BIT TEST FAILURE (-PROM CHECKSUM FAULT  -RAM FAULT -AC SUPPLY HARD FAULT  <cr><lf><eos>
<b>STA</b> <cr><lf><eos>	Status. Prepares AC Power Supply for a response transmission. Clears error condition if one exists. The following response messages and conditions exclude confidence and internal self test.
RESPONSE:	<u>Status OK</u> <sp><cr><lf><eos>
	<u>Device error messages</u>  F07ACSO(DEV):BIT TEST FAILURE <description consisting of up to 60 characters><cr><lf><eos>
	<u>TMA error messages</u> All begin with:  F07ACSO (MOD):  This message is followed by one explanatory message from the following text:  ILLEGAL NOUN  AC Power Supply does not recognize illegal noun.  ILLEGAL NOUN MODIFIER  AC Power Supply does not recognize illegal noun modifier.  ILLEGAL OPCODE  AC Power Supply does not recognize illegal opcode.  ILLEGAL VALUE  Entered value lies outside upper and lower limits.  NO SETUP Close command received but setup not programmed.  Example: F07ACS00(MOD): NO SETUP <cr><lf><eos>

## 1.5 CATASTROPHIC ERRORS

A catastrophic failure is generated each time the AC Power Supply experiences a hardware failure. Errors are cleared whenever the AC Power Supply transmits a response, except in the case of a short circuit fault which may only be cleared by cycling power to the AC Supply.

### Catastrophic Error Messages

All begin with:

F00ACS0(DEV):

This message is followed by one explanatory message from the following text:

OVERTEMP FAULT <cr><lf><eos>

The heatsink temperature has exceeded its upper limit. The OVERTEMP LED on the front panel will light.

CURRENT LIMIT FAULT <cr><lf><eos>

SHORT CIRCUIT FAULT: AC SUPPLY<cr><lf><eos>

An output loading fault has occurred causing the supply to exceed 500% rated current output. The supply automatically shuts down and opens its output relay. The OVERLOAD LATCH LED on the front panel will light.

## EIA-232 SERIAL PROGRAMMING EXAMPLES

Examples of actual command strings transmissions and typical responses are outlined below.

All commands must be in upper case ASCII, lower case characters are ignored. All commands transmitted to the AC SUPPLY must terminate with a carriage return <cr> and a line feed <lf>, and <eos> as will all responses received from the AC SUPPLY.

**1. EXAMPLE:** Setup a single range AC Source to output 120 V @60 Hz, and close the output relay.

Transmit setup command:

FNC ACS :CHO SET VOLT 120 SET FREQ 60<cr><lf><eos>

Transmit status command to request status response:

STA <cr><lf><eos>

Talk address the AC Source to enable response:

<space><cr><lf><eos>

: Positive response indicating status is OK.

F07ACS00 (MOD) ILLEGAL VALUE <cr><lf>: Negative response indicating error condition.

(Typically a negative response would only occur if an error existed in the entry or reception of the command string, or the values entered were out of range of the AC Source).

Transmit output relay close command:

CLS :CHO <cr><lf><eos>

Transmit status command to request status response:

STA <cr><lf><eos>

Talk address the AC Source to enable response:

<space><cr><lf><eos>

: Positive response indicating status is OK.

F07ACS00 (MOD) NO SETUP <cr><lf> : Negative response indicating error condition.

(Negative response would only occur if invalid or no setup string had been transmitted prior to close command).

**2. EXAMPLE:** Setup a dual range AC Source to output 30 V on low range @400 Hz.

Transmit setup command:

FNC ACS :CHO SET VOLT 30 SET FREQ 400 SET VLTO <cr><lf><eos>

Transmit status command to request status response:

STA <cr><lf><eos>

Talk address the AC Source to enable response:

<space><cr><lf><eos>

: Positive response indicating status is OK.

## EIA-232 SERIAL PROGRAMMING EXAMPLES

3. EXAMPLE: Setup a dual range AC Source to output 115 V on high range @50 Hz, and read back what the actual voltage, current, and frequency being output is set at.

Transmit setup command:

```
FNC ACS :CHO SET VOLT 115 SET FREQ 50 SET VLT1 <cr><lf><eos>
```

Transmit status command to request status response:

```
STA <cr><lf><eos>
```

Talk address the AC Source to enable response:

```
<space><cr><lf><eos>
```

: Positive response indicating status is OK.

Transmit output relay close command:

```
CLS :CHO <cr><lf><eos>
```

Transmit status command to request status response:

```
STA <cr><lf><eos>
```

Talk address the AC Source to enable response:

```
<space><cr><lf><eos>
```

: Positive response indicating status is OK.

Transmit fetch volt command:

```
FTH VOLT <cr><lf><eos>
```

Talk address the AC Source to enable response:

```
115.0 <cr><lf><eos>
```

Transmit fetch current command:

```
FTH CURR <cr><lf><eos>
```

Talk address the AC Source to enable response:

```
5.2 <cr><lf><eos>
```

Transmit fetch frequency command:

```
FTH FREQ <cr><lf><eos>
```

Talk address the AC Source to enable response:

```
50 <cr><lf><eos>
```



**SECTION 6**

**PARTS LIST AND DRAWINGS**

**CONTROL CHASSIS ASSEMBLY**

107-909-006

**PROPRIETARY**  
 THE INFORMATION CONTAINED HEREIN IS UNCLASSIFIED  
 BUT NOT BE DISCLOSED TO OTHERS FOR ANY PURPOSE, NOR  
 USED FOR MANUFACTURING PURPOSES WITHOUT PERMISSION OF  
 BEHLMAN ELECTRONICS, INC.  
 BEHLMAN ELECTRONICS, INC.  
 HARTFORD, CONNECTICUT 06105

ZONE	LTR	DESCRIPTION	DATE	APPROVED
A	ADDED	CAP BOARD ASSY PER ECO 96-019	96-06-07	RKL
B	ROTATED	K1	98-02-20	RKL
C	REVISED	PER ECO 98-018	99-03-08	RKL
D	REVISED	PER ECO 98-108	99-03-09	RKL
E	REVISED	PER ECO 01-007	01-01-26	RKL
F	REVISED	PER ECO 09-047 (FM)	04-15-09	RKL
G	REVISED	PER ECO 13-009 (FM)	3-05-13	RKL

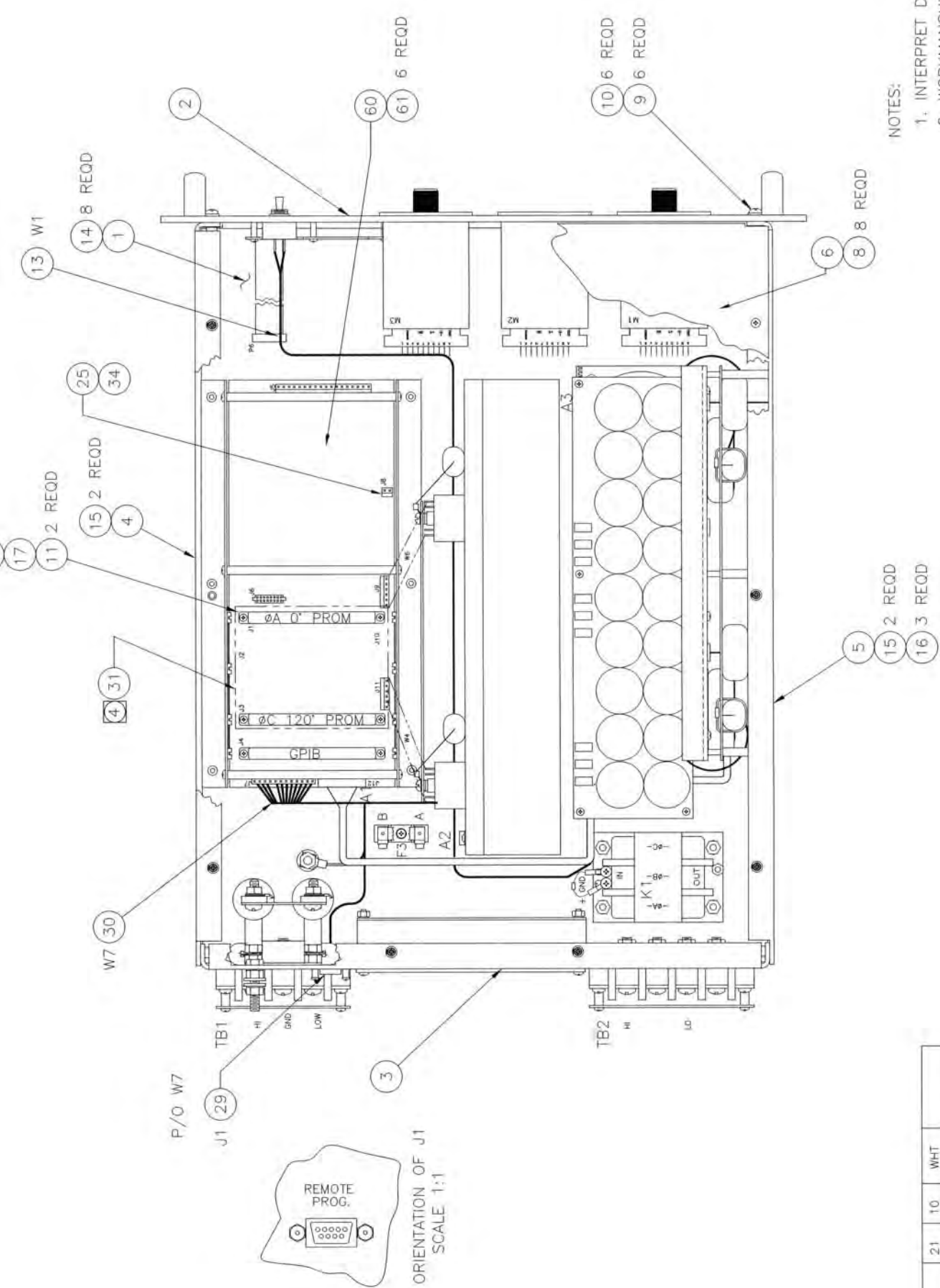

CONTROLLED DOCUMENT

- NOTES:
- INTERPRET DRAWING I.A.W. MIL-STD-100.
  - WORKMANSHIP SHALL BE I.A.W. MIL-HDBK-454, GUIDELINE 9.
  - THIS ASSEMBLY CONTAINS PARTS SENSITIVE TO DAMAGE BY ELECTROSTATIC DISCHARGE (ESD). USE ESD PRECAUTIONARY PROCEDURES WHEN ASSEMBLING OR HANDLING PER MIL-HDBK-263 AND MIL-STD-1686, CLASS 1. ALL WORK TO BE PERFORMED AT STATIC SAFE WORK STATIONS.
  - ADHERE ITEM 31 (1/8" THICK GRAY FOAM 4.50 X 3.60) TO UNDERSIDE OF TOP COVER, LINING UP WITH PHASE CARDS.

THIS DRAWING SHALL ONLY BE CHANGED BY USE OF CAD		DATE	
DRAWN	L. MORRELL	DATE	01-01-26
CHECKED	<i>[Signature]</i>	DATE	01/13
ENGR.	<i>[Signature]</i>	DATE	3/14/13
QUALITY CONTROL		DATE	
MANUFACTURING		DATE	

UNLESS OTHERWISE SPECIFIED DIMENSIONS ARE IN INCHES
TOLERANCES: FRAC ±.005
2 PLACE DEC ±.01
ANGLES ±.1°
DO NOT SCALE THIS DWG
MATERIAL:
106-676-BXX
USED ON

THIS DRAWING SHALL ONLY BE CHANGED BY USE OF CAD	DATE
DRAWN	01-01-26
CHECKED	01/13
ENGR.	3/14/13
QUALITY CONTROL	
MANUFACTURING	

CODE	REV
D	53636
106-909-006	G

CONN NO.	FROM	TO	LUG ITEM NO.	AWG	COLOR	COMMENTS
14	TB2-COM	21	NEUT STUD	21	WHT	
13	A3A1E5	21	NEUT STUD	21	WHT	
12	F3-B	20	F1-A	25	RED	
11	A3L6-OUT	-	K1-HI IN	10	WHT	
10	A3L4-OUT	-	K1-LO IN	10	WHT	
9	K1 COIL GND	23	NEUT STUD	21	BLK	
8	A3A1-E7	23	NEUT STUD	21	WHT	
7	K1-LO OUT	21	TB2-LO	21	BLK	LO
6	K1-HI OUT	21	TB2-HI	21	BLK	HI
5	GND STD	21	A1J8-2	25	WHT	NEUT
4	F2-A	21	A206-E2	21	ORN	-250V
3	TB1-GND	21	NEUT STUD	21	WHT	NEUT
2	F1-A	21	A205-C1	21	RED	+250V
1	F3-A	20	A1J8-1	25	RED	+250V

**BEHLMAN**  
 ASSY, CONTROL CHASSIS  
 BL6,000

SEE SEPARATE PARTS LIST

**CONTROL CHASSIS SCHEMATIC**

106-951-017 (standard)  
106-951-015 (T6D option)

CONTROLLED DOCUMENT

ZONE	LTR	DESCRIPTION	DATE	APPROVED	DRG.#	INT.
1		INITIAL RELEASE	4/1/58	[Signature]	13265	075

DATE	BY	REVISION
4/1/58	[Signature]	1

DATE	BY	REVISION
4/1/58	[Signature]	1

DATE	BY	REVISION
4/1/58	[Signature]	1

DATE	BY	REVISION
4/1/58	[Signature]	1

DATE	BY	REVISION
4/1/58	[Signature]	1

DATE	BY	REVISION
4/1/58	[Signature]	1

DATE	BY	REVISION
4/1/58	[Signature]	1

DATE	BY	REVISION
4/1/58	[Signature]	1

DATE	BY	REVISION
4/1/58	[Signature]	1

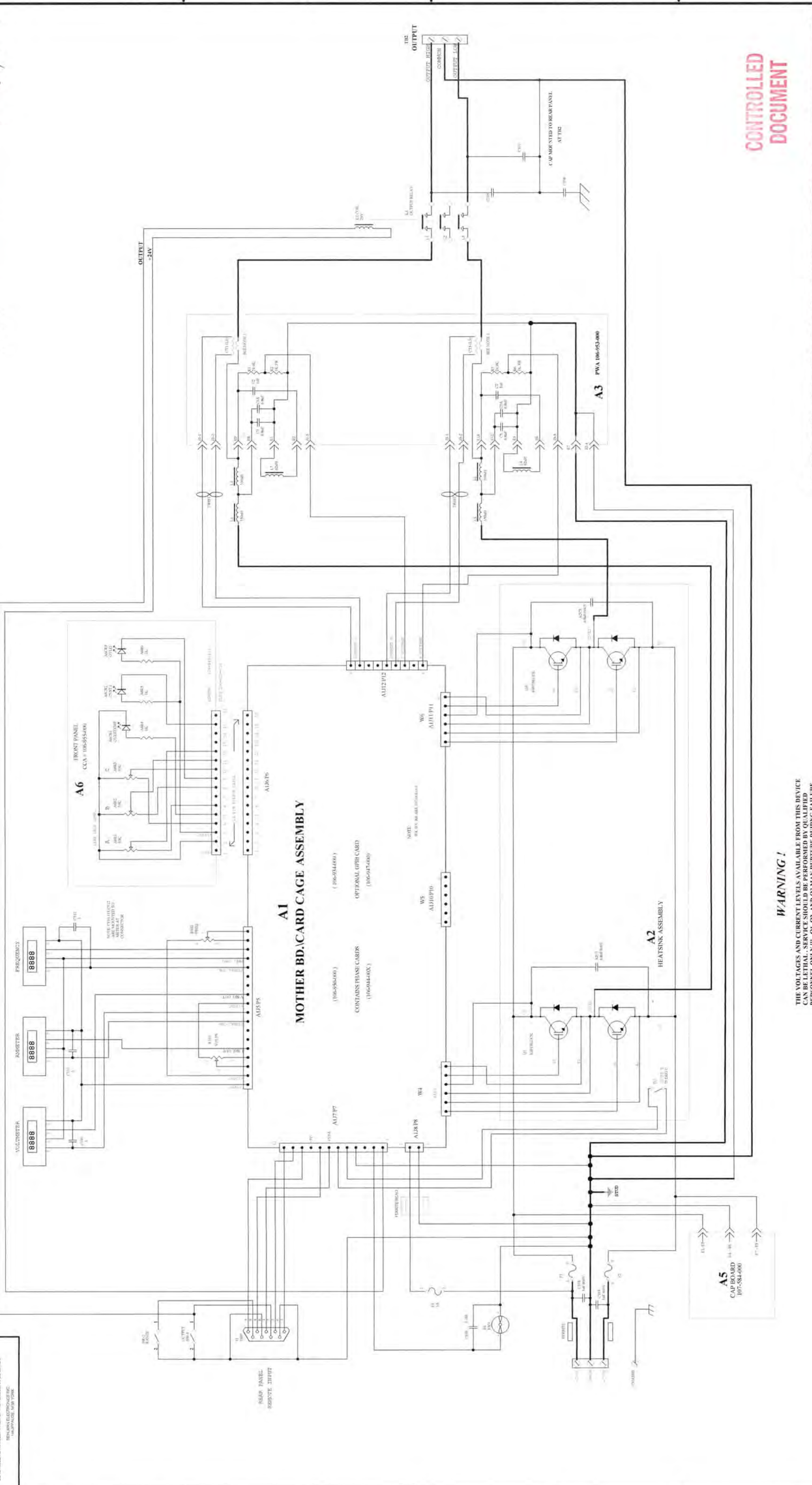

WARNING!

THE VOLTAGES AND CURRENT LEVELS AVAILABLE FROM THIS DEVICE CAN BE LETHAL. SERVICE SHOULD BE PERFORMED BY QUALIFIED PERSONNEL ONLY !!! Q1, Q2, AND Q3 MAY RIPTURE DURING FAILURE CAUSING PERSONAL INJURY. USE CAUTION WHEN TESTING AND PROBING THIS DEVICE !!!

THIS DRAWING SHALL ONLY BE CHANGED BY USE OF CAD		CHECKED S. BOGLE	DATE 4/1/58	DRAWN S. BOGLE	DATE 4/1/58
DIMENSIONS UNLESS OTHERWISE SPECIFIED TO BE IN INCHES TOLERANCES: FINISHES: ANNOTATIONS: MATERIAL: DO NOT SCALE THIS DRAWING	THIS DRAWING SHALL ONLY BE CHANGED BY USE OF CAD	CHECKED S. BOGLE	DATE 4/1/58	DRAWN S. BOGLE	DATE 4/1/58
NEXT ASSY.	USED ON	PART NO. 106-951-017	DATE 4/1/58	CHECKED S. BOGLE	DATE 4/1/58
APPLICATION		PART NO. 106-951-017	DATE 4/1/58	CHECKED S. BOGLE	DATE 4/1/58

PROPRIETARY  
 THE PROPRIETARY INFORMATION CONTAINED IN THIS DOCUMENT MAY BE DISCLOSED TO OTHERS FOR ANY PURPOSE, NOW OR IN THE FUTURE, WITHOUT THE WRITTEN PERMISSION OF BEHLMAN ELECTRONICS, INC. THE ACCEPTANCE OF THIS DOCUMENT SHALL BE CONSIDERED AS AN ACCEPTANCE OF THE FOREGOING CONDITIONS.  
 BEHLMAN ELECTRONICS, INC.  
 HARTFORD, CONNECTICUT

**MOTHERBOARD**

106-948-000 (Schematic Diagram)

REV	STATUS OF SHI	DESCRIPTION	DATE	APPROVED
1				
2				
3				
4				
5				
6				
7				
8				

ZONE	LTR	DESCRIPTION	DATE	APPROVED
A		REVISED AND REDRAWN	1-29-73	
B		ECO 93-031	3/15/73	
C		R44 FROM 21.5 TO 43.2K. R45 FROM 21.0 TO 22.0	3/15/73	
D		C25 FROM 680P TO 330P	3/15/73	
E		ECO 93-075	3/15/73	
F		REVISED PER ECO 96-055	96-10-24	
G		REVISED PER ECO 97-009	97-08-12	
H		REVISED PER ECO 99-079	99-06-23	
I		REVISED PER ECO 01-034	01-09-77	

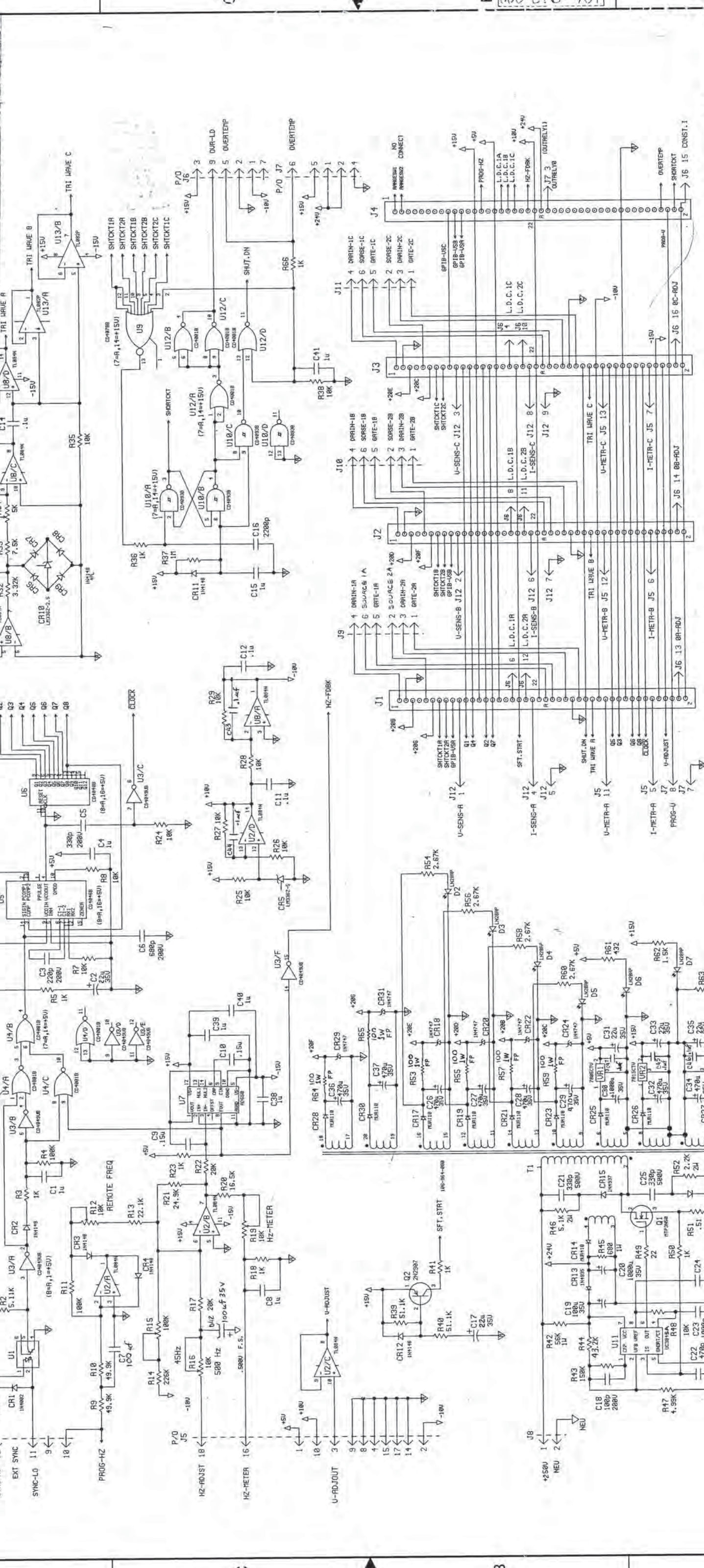

**BEHLMAN**  
An AstroSystems Company

**SCHEM DIAG**  
**MOTHER BOARD**  
**3 PHASE**

CONTRACT: 106-948-000

DRAWN: S. BOTTIGLIERE  
CHECKED: [Signature]  
ENGR: [Signature]

DATE: 1-29-73

SCALE: 1 OF 1

SIZE: D 53636

CODE IDENT NO.: 106-948-000

REV: J

UNLESS OTHERWISE SPECIFIED DIMENSIONS ARE IN INCHES. TOLERANCES: FRACTIONS ± 3 PLACE DECIMALS ± 2 PLACE DECIMALS ± ANGLES ± DO NOT SCALE THIS DRAWING MATERIAL: 106-676-800 BLANK US'D ON

HIGHEST REF DES: U13, CR31, R66, C47, D2-D8

**PHASE CONTROL BOARD**

106-948-000 (schematic diagram)



**PROPRIETARY**  
 THE PROPRIETARY INFORMATION CONTAINED IN THIS DOCUMENT SHALL NOT BE DISCLOSED OR REPRODUCED FOR ANY PURPOSE NOR FOR ANY INFORMATION SYSTEMS PURPOSES, WITHOUT PERMISSION OF BEHLMAN ELECTRONICS, INC. THE ACCEPTANCE OF THIS DOCUMENT WILL BE CONSTRUED AS AN ACCEPTANCE OF THE FOREGOING CONDITION.  
 BEHLMAN ELECTRONICS, INC.  
 HAUPPAUGE, NEW YORK

ZONE	LTR	DESCRIPTION	DATE	APPD
J		REVISED PER ECO 98-034	980831	S.B.
K		REVISED PER ECO 00-190	10-28-00	S.B.

ZONE	LTR	DESCRIPTION	DATE	APPD
B		ECO 93-033	3/15/93	S.B.
C		R31,50 FROM 33.2K C25,27 FROM 100P	96-10-24	S.B.
D		REVISED PER ECO 96-007	96-10-24	S.B.
E		REVISED PER ECO 96-043	96-10-24	S.B.
F		REVISED PER ECO 96-044	96-10-24	S.B.
G		REVISED PER ECO 97-054	97-08-15	S.Boyle
H		REVISED PER ECO 98-032	98-08-03	S.Boyle

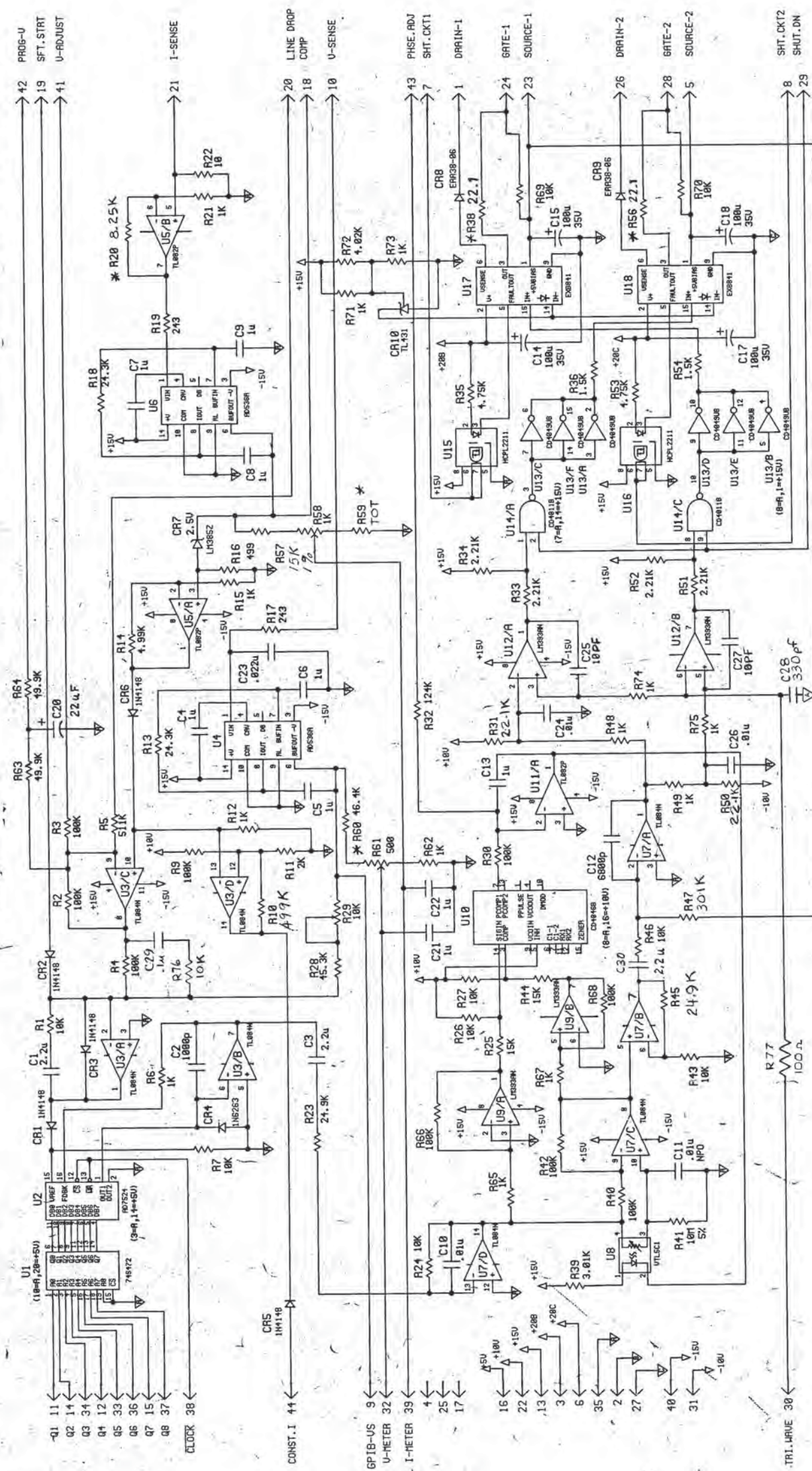

**BEHLMAN**  
 An AstroSystems Company

**SCHEM DIAG**  
**PHASE CONTROL DRIVER**  
**3 PHASE BL**

UNLESS OTHERWISE SPECIFIED  
 DIMENSIONS ARE IN INCHES  
 TOLERANCES: FRACTIONS ±  
 3 PLACE DECIMALS ±  
 2 PLACE DECIMALS ±  
 ANGLES ±

DO NOT SCALE THIS DRAWING

MATERIAL:

CONTRACT

DRAWN: BOTTGLIERE 11-20-92  
 DATE: 11-20-92

CHECKED: [Signature] 10-26-00  
 ENGR: [Signature] 11-24-92

SIZE: C 53636  
 CODE IDENT NO. 06-942-000  
 REV K

FROM NOT USED  
 R7 R8, 37, 55  
 U18 U1  
 C30 C16, C19  
 CR10

\*SEE SAT MATRIX SCD (107-850-000)  
 FOR R20, R59, R56, R38, & R60 VALUES

APPLICATION

NEXT ASSY USED ON: 106-944-000, BL101

SCALE: 1 OF 1

1  
2  
3  
4

106-942-000

**POWER CHASSIS**

106-977-1XX POWER CHASSIS ASSEMBLY ( 3 PHASE )

**PROPRIETARY**  
 THE PROPRIETARY INFORMATION CONTAINED IN THIS DOCUMENT IS THE PROPERTY OF BEHLMAN ELECTRONICS, INC. AND IS NOT TO BE REPRODUCED OR TRANSMITTED IN ANY FORM OR BY ANY MEANS, ELECTRONIC OR MECHANICAL, INCLUDING PHOTOCOPYING, RECORDING, OR BY ANY INFORMATION STORAGE AND RETRIEVAL SYSTEM, WITHOUT THE WRITTEN PERMISSION OF BEHLMAN ELECTRONICS, INC. THE ACCEPTANCE OF THIS DRAWING BY THE BUYER SHALL BE HELD AS AN ACCEPTANCE OF THE FOREGOING CONDITION.  
 BEHLMAN ELECTRONICS, INC.  
 HEMPSTEAD, NEW YORK

ZONE	LTR	DESCRIPTION	DATE	APPROVED
-	-	RELEASED FOR PRODUCTION	920729	RA
A	-	REVISED WIRE RUN SCHEDULE	931122	RA
B	-	REVISED PER ECO 93-080	950727	RA
C	-	REVISED WIRE RUN SCHEDULE	951022	RA
D	-	REVISED PER ECO96-049 & 96-063	980706	RA
E	-	REVISED PER ECO98-084	030519	RA
F	-	REVISED PER ECO03-036	030912	RA
G	-	REVISED PER ECO03-117	1-13-15	RA
H	-	REVISED PER ECO04-213		
J	-	REVISED PER ECO04-213		

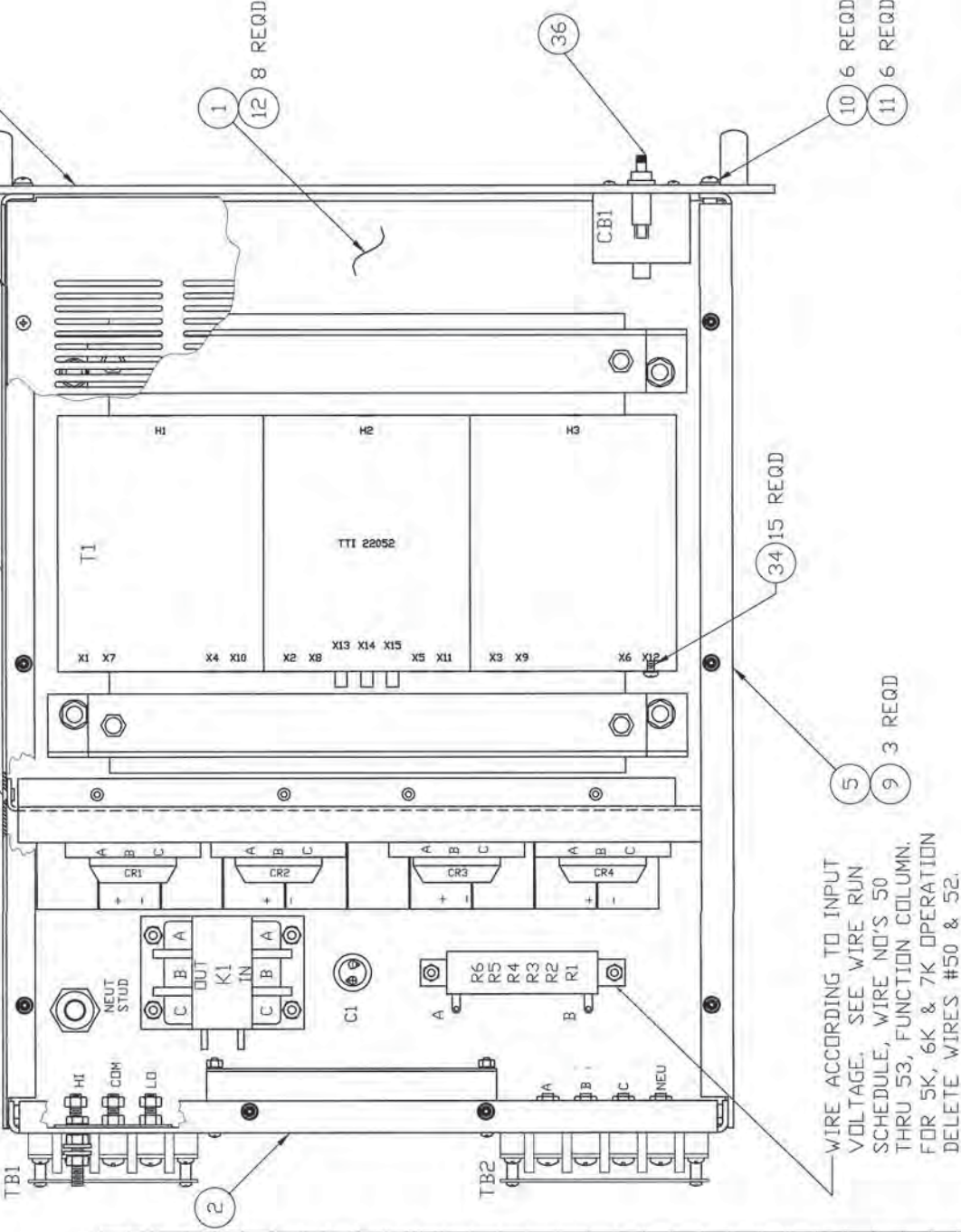

CONN NO.	FROM	TO	LUG ITEM NO.	AWG	COLOR	FUNCTION
48	C1-	-	K1 COIL-	18	WHT	
47	K1 OUT-B	15	T1-H2	16	BLK	
46	K1 OUT+A	15	T1-H1	16	RED	
45	R4B	-	K1 OUT-B	15	BLK	
44	R2B	-	K1 OUT+A	15	RED	
43	R3A	-	K1 IN-B	15	BLK	
42	R1A	-	K1 IN+A	15	RED	
41	TB2-NEUT	-	NC	-	-	
40	TB1-COM	14	NEUT STUD	14	BLK	
39	CR2-	15	NEUT STUD	14	WHT	
38	A1E4	23	NEUT STUD	14	BLK	
37	A1E3	23	NEUT STUD	14	BLK	
36	T1-X3	22	INDICATOR LIGHT	21	WHT	
35	T1-X1	22	INDICATOR LIGHT	21	BLK	
34	A1E6	23	TB1 - (L3)	14	BLK	
33	A1E5	23	TB1 - (L0)	14	BLK	
32	A1E2	23	TB1 + (HI)	14	RED	
31	A1E1	23	TB1 + (HI)	14	RED	
30	K1 COIL +	18	A1EB	19	WHT	
29	K1 COIL -	18	A1E7	19	WHT	
28	CR4-	15	TB1 - (L0)	14	BLK	
27	CR1+	15	TB1 + (HI)	14	RED	
26	CR3-	15	CR4 +	15	BLK	
25	CR2-	15	CR3 +	15	BLK	
24	CR1-	15	CR2 +	15	BLK	
23	A1J1-2	39,40	FAN -	20	BLK	
22	A1J1-1	39,40	FAN +	20	RED	
21	T1-X14	19	A1 J1-3	39,40	RED	
20	T1-X15	19	A1 J1-4	39,40	BLK	
19	T1-X13	19	A1 J1-5	39,40	RED	
18	T1-X12	16	CR4-0C	15	BRN	
17	T1-X11	16	CR4-0B	15	BRN	
16	T1-X10	16	CR4-0A	15	BRN	
15	T1-X9	16	CR3-0C	15	BRN	
14	T1-X8	16	CR3-0B	15	BRN	
13	T1-X7	16	CR3-0A	15	BRN	
12	T1-X6	16	CR2-0C	15	BRN	
11	T1-X5	16	CR2-0B	15	BRN	
10	T1-X4	16	CR2-0A	15	BRN	
9	T1-X3	16	CR1-0C	15	BRN	
8	T1-X2	16	CR1-0B	15	BRN	
7	T1-X1	16	CR1-0A	15	BRN	
6	CB1-0C (D)	-	K1 IN C	15	WHT	
5	CB1-0B (D)	-	K1 IN B	15	WHT	
4	CB1-0A (D)	-	K1 IN A	15	WHT	
3	TB2-0C	14	CB1-0C (A)	-	WHT	
2	TB2-0B	14	CB1-0B (A)	-	WHT	
1	TB2-0A	14	CB1-0A (A)	-	WHT	

NOTES:  
 1. INTERPRET DRAWING I.A.W. MIL-STD-100.  
 2. WORKMANSHIP SHALL BE I.A.W. IPC-A-610, CLASS 2.

3. THIS ASSEMBLY CONTAINS PARTS THAT ARE SENSITIVE TO DAMAGE BY ELECTROSTATIC DISCHARGE (ESD). USE ESD PRECAUTIONARY PROCEDURES WHEN ASSEMBLING AND AND WIRING PER MIL-HDBK-263 AND MIL-STD-1686 CLASS 1.  
 4. PART MARK ASSEMBLY 53636 106-977-1XX WITH APPROPRIATE DASH NUMBER AND CURRENT REVISION STATUS USING THE BAG AND TAG METHOD. PER MIL-STD-130.

SEE SEPARATE PARTS LIST



**CONTROLLED  
 DOCUMENT**

THIS DRAWING SHALL ONLY BE CHANGED BY USE OF CAD		DATE
DRAWN	J. ALGERIO	920727
CHECKED		
ENGR	R. J. J. J.	11/3/15
QUALITY CONTROL		
MANUFACTURING		

UNLESS OTHERWISE SPECIFIED DIMENSIONS ARE IN INCHES	DO NOT SCALE THIS DWG	MATERIAL
TOLERANCES: FRACTIONAL PLACE DEC ±0.01	DO NOT SCALE THIS DWG	
ANGLES ±1°		
106-676-BXX	BL10K	USED DN
NEXT ASSY		

SIZE	CODE IDENT NO.	SCALE	CAD FILE
D	53636	106-977-1XX	106-977-1XX.JDWG

REV	DATE
J	

**BEHLMAN**

POWER CHASSIS ASSY  
 10K

**POWER CHASSIS**

106-956-006 3 PHASE (Schematic Diagram)  
106-956-009 1 PHASE ( Schematic Diagram)

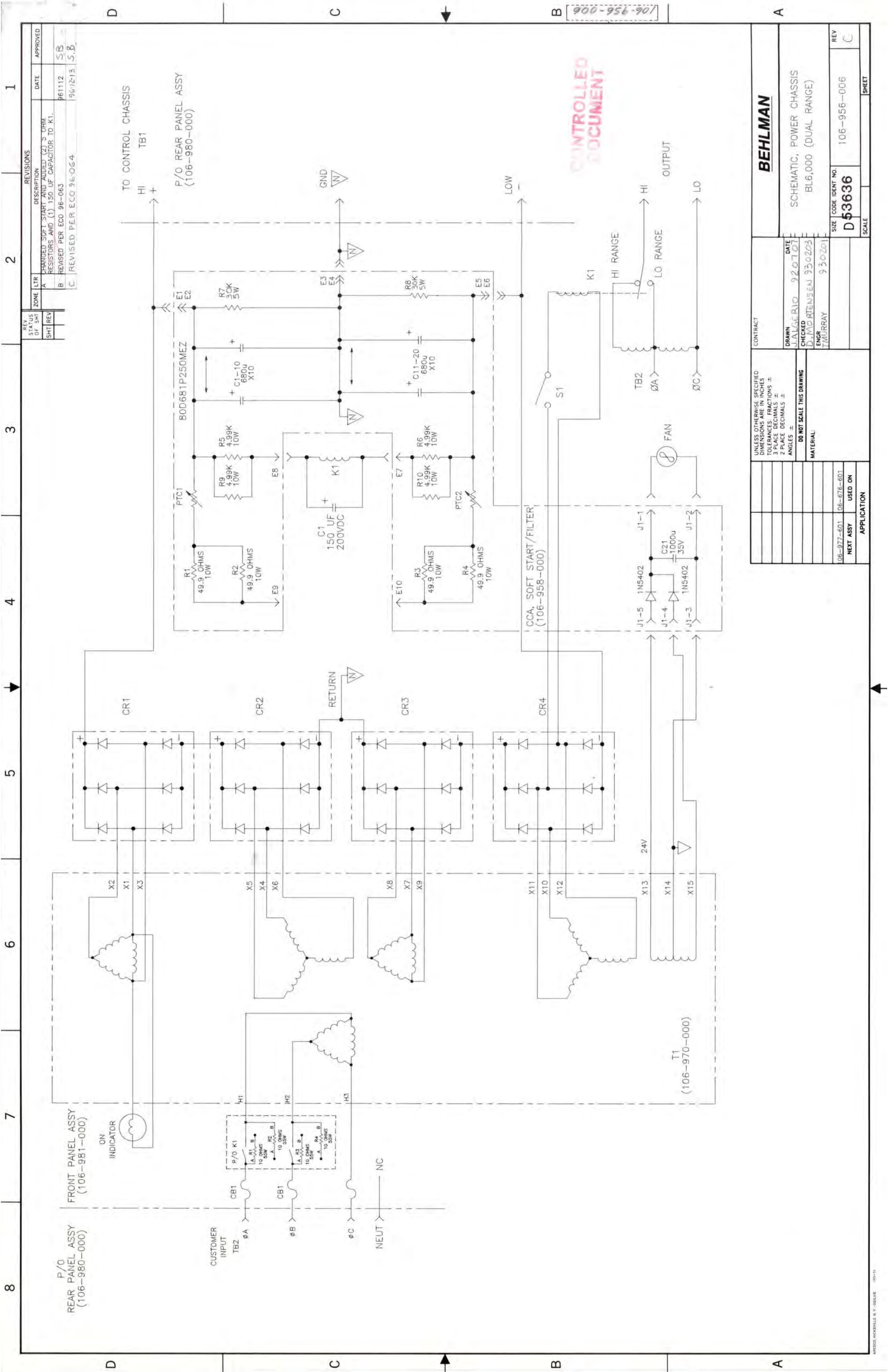

CONTROLLED DOCUMENT

REV	STATUS	ZONE	DATE	DESCRIPTION	APPROVED
A	CHANGED	SOFT START AND ADDED (2) 5 OHM RESISTORS AND (1) 150 UF CAPACITOR TO K1.	9/6/11	SB	
B	REVISED	PER ECO 96-063	9/6/11	SB	
C	REVISED	PER ECO 96-064	9/6/11	SB	

CONTRACT		DATE	
UNLESS OTHERWISE SPECIFIED DIMENSIONS ARE IN INCHES		DRAWN J. ALGERIO 9/20/07	
TOLERANCES: FRACTIONS ±		CHECKED D. MURRAY 9/30/07	
1 PLACE DECIMALS ±		ENGR. T. MURRAY 9/30/07	
2 PLACE DECIMALS ±		MATERIAL:	
ANGLES ±		DO NOT SCALE THIS DRAWING	
APPLICATION		SIZE CODE IDENT NO. D53636	
NEXT ASSY USED ON		SCALE	
06-977-601 06-676-601		SHEET	
106-977-601 06-676-601		REV C	
106-977-601 06-676-601		106-956-006	

**BEHLMAN**

SCHEMATIC, POWER CHASSIS  
BL6,000 (DUAL RANGE)

106-956-006  
REV C

**OUTLINE CONTROL CHASSIS**

106-909-508

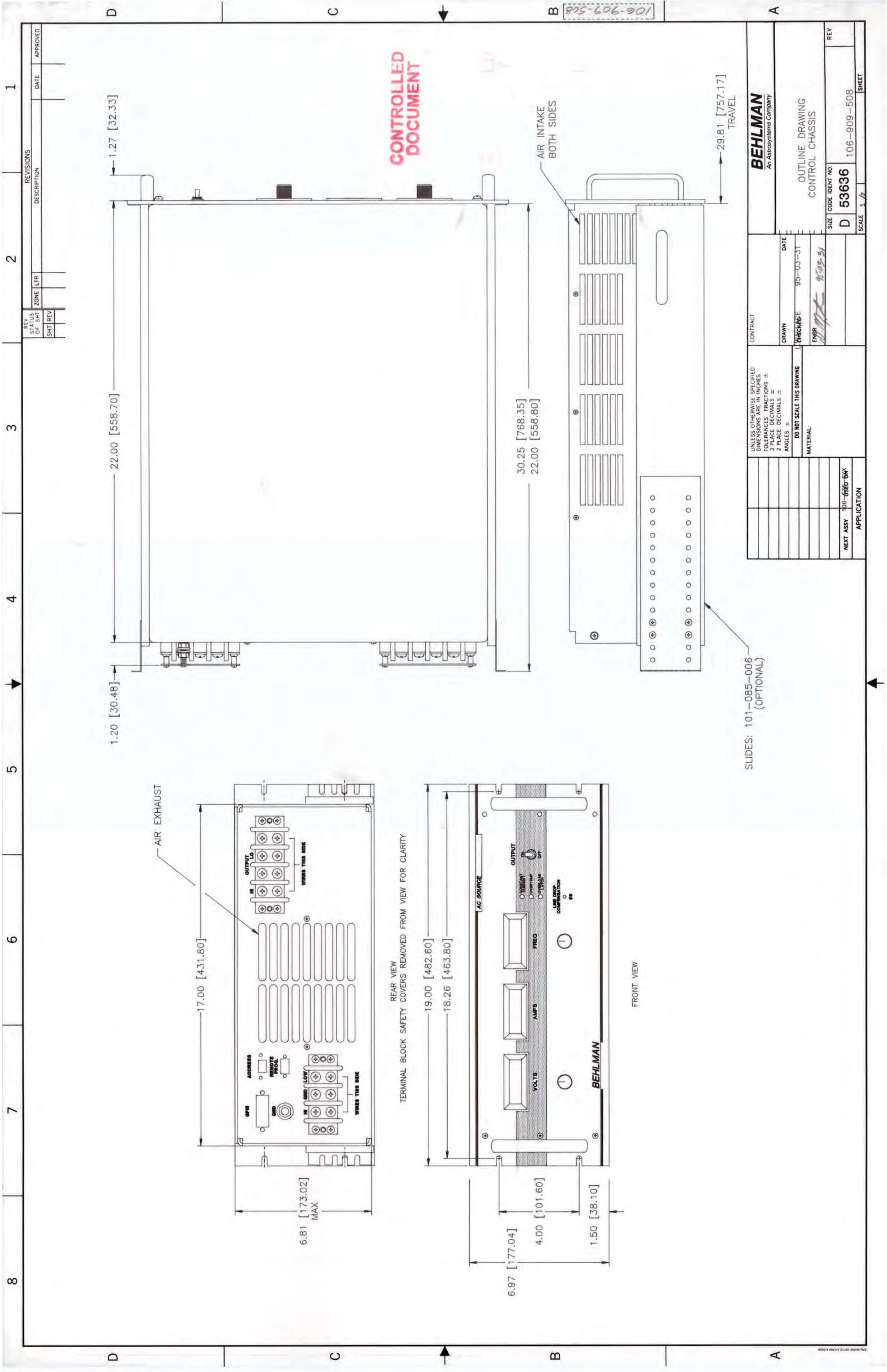

REV	STATUS OF SHT	ZONE	LTR	DESCRIPTION	DATE	APPROVED

<b>BEHLMAN</b> An AstroSystems Company		CONTRACT	DATE
OUTLINE DRAWING CONTROL CHASSIS		DRAWN	95-03-31
UNLESS OTHERWISE SPECIFIED DIMENSIONS ARE IN INCHES TOLERANCES: FRACTIONS ± 3 PLACE DECIMALS ± 2 PLACE DECIMALS ± ANGLES ±	DO NOT SCALE THIS DRAWING	CHECKED	95-03-31
MATERIAL:		ENGR	95-03-31
NEXT ASSY	106-686D BK	SIZE	CODE IDENT NO.
APPLICATION		D	53636
		SCALE	106-909-508
			SHEET

**OUTLINE POWER CHASSIS**

106-909-500 ( 3 PHASE INPUT)



**PROPRIETARY**  
 THE INFORMATION CONTAINED IN THIS DOCUMENT IS UNCLASSIFIED EXCEPT WHERE SHOWN OTHERWISE. IT IS THE PROPERTY OF BEHLMAN ELECTRONICS INC. AND IS NOT TO BE DISCLOSED OR USED FOR MANUFACTURING PURPOSES WITHOUT PERMISSION OF BEHLMAN ELECTRONICS INC. THIS DOCUMENT IS UNCLASSIFIED EXCEPT WHERE SHOWN OTHERWISE. IT IS THE PROPERTY OF BEHLMAN ELECTRONICS INC. AND IS NOT TO BE DISCLOSED OR USED FOR MANUFACTURING PURPOSES WITHOUT PERMISSION OF BEHLMAN ELECTRONICS INC.

ZONE	LTR	DESCRIPTION	DATE	APPROVED
-	-	RELEASED FOR PRODUCTION	08-28-14	[Signature]

ZONE	LTR	DESCRIPTION	DATE	APPROVED
-	-	RELEASED FOR PRODUCTION	08-28-14	[Signature]

D C B A

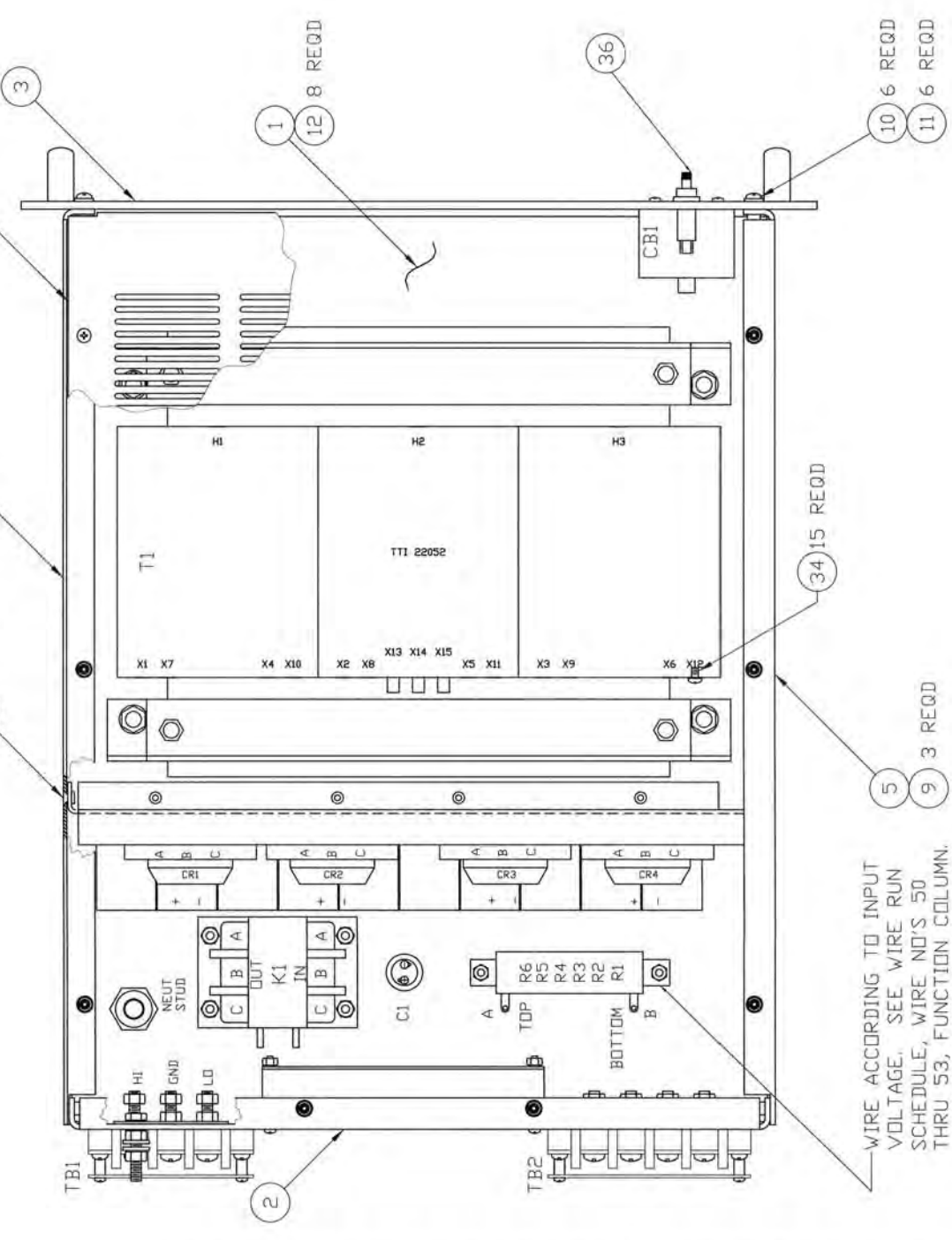

**CONTROLLED DOCUMENT**

NOTES:  
 1. INTERPRET DRAWING I.A.W. MIL-STD-100.  
 2. WORKMANSHIP SHALL BE I.A.W. MIL-HDBK-454, GUIDELINE 9.  
 3. THIS ASSEMBLY CONTAINS PARTS THAT ARE SENSITIVE TO DAMAGE BY ELECTROSTATIC DISCHARGE (ESD). USE ESD PRECAUTIONARY PROCEDURES WHEN ASSEMBLING AND WIRING PER MIL-HDBK-263 AND MIL-STD-1686 CLASS 1.  
 4. PART MARK ASSEMBLY WITH PART NUMBER AND CURRENT REVISION STATUS USING THE BAG AND TAG METHOD. PER MIL-STD-130.

SEE SEPARATE PARTS LIST

CONN NO.	FROM	LUG ITEM NO.	TO	AWG	COLOR	FUNCTION
48	C1-		K1 COIL-	19	20	WHT
47	K1 OUT-B		T1-H2	15	10	BLK
46	K1 OUT+A		T1-H1	15	10	RED
45	R4B		K1 OUT-B	10		BLK
44	R2B		K1 OUT +A	10		RED
43	R3A		K1 IN-B	10		BLK
42	R1A		K1 IN+A	10		RED
41	TB2-NEUT		NC	14	12	BLK
40	TB1-GND		NEUT STUD	14	10	BLK
39	CR2 -		NEUT STUD	21	10	WHT
38	A1E4		NEUT STUD	14	12	BLK
37	A1E3		NEUT STUD	14	12	BLK
36	T1 X3		INDICATOR LIGHT	21	20	WHT
35	T1-X1		INDICATOR LIGHT	21	20	BLK
34	A1E6		TB1 - (LO)	14	12	BLK
33	A1E5		TB1 - (LO)	14	12	BLK
32	A1E2		TB1 + (HI)	14	12	RED
31	A1E1		TB1 + (HI)	14	12	RED
30	K1 COIL +		A1E8	19	20	WHT
29	K1 COIL -		A1E7	19	20	WHT
28	CR4-		TB1 - (LO)	14	10	BLK
27	CR1+		TB1 + (HI)	14	10	RED
26	CR3 -		CR4 +	16	10	BLK
25	CR2 -		CR3 +	16	10	BLK
24	CR1 -		CR2 +	16	10	BLK
23	J1-2		FAN -	20	20	BLK
22	J1-1		FAN +	20	20	RED
21	T1-X14		A1 J1-3	19	20	RED
20	T1-X15		A1 J1-4	19	20	BLK
19	T1-X13		A1 J1-5	19	20	RED
18	T1-X12		CR4-#C	15	12	BRN
17	T1-X11		CR4-#B	15	12	BRN
16	T1-X10		CR4-#A	15	12	BRN
15	T1-X9		CR3-#C	15	12	BRN
14	T1-X8		CR3-#B	15	12	BRN
13	T1-X7		CR3-#A	15	12	BRN
12	T1-X6		CR2-#C	15	12	BRN
11	T1-X5		CR2-#B	15	12	BRN
10	T1-X4		CR2-#A	15	12	BRN
9	T1-X3		CR1-#C	15	12	BRN
8	T1-X2		CR1-#B	15	12	BRN
7	T1-X1		CR1-#A	15	12	BRN
6	CB1-#C (D)		K1 IN C	15	10	WHT
5	CB1-#B (D)		K1 IN B	15	10	WHT
4	CB1-#A (D)		K1 IN A	15	10	WHT
3	TB2-#C		CB1-#C (A)	14	10	WHT
2	TB2-#B		CB1-#B (A)	14	10	WHT
1	TB2-#A		CB1-#A (A)	14	10	WHT
CONN NO.	FROM	LUG ITEM NO.	TO	AWG	COLOR	FUNCTION
62	R5-B		R6-A			14 BUSS WIRE FOR C2,3,5,6,7
61	R5-B		R6-B			14 BUSS WIRE FOR C1,C4
60	R5-A		R6-A			14 BUSS WIRE FOR C1,C4
59	K1 OUT-C		T1H-3			10 WHT
58	R6-B		K1 OUT C			10 ORG
57	R5-A		K1 IN C			10 BLU
56	TB2N		T1N			10 WHT
55	R3-B		R4-A			14 BUSS WIRE C-2,C-3,C-5, C-6,C-7
54	R1-B		R2-A			14 BUSS WIRE C-1,C-4
53	R3-B		R4-B			14 BUSS WIRE C-1,C-4
52	R3-A		R4-A			14 BUSS WIRE C-1,C-4
51	R1-B		R2-B			14 BUSS WIRE C-1,C-4
50	R1-A		R2-A			14 BUSS WIRE C-1,C-4
49	C1+		K1 COIL+			19 20 WHT
CONN NO.	FROM	LUG ITEM NO.	TO	AWG	COLOR	FUNCTION

THIS DRAWING SHALL ONLY BE CHANGED BY USE OF CAD	DATE	BY
DRAWN	08-27-14	[Signature]
CHECKED	08-27-14	[Signature]
ENGR	08-27-14	[Signature]
QUALITY CONTROL	08-27-14	[Signature]
MANUFACTURING	08-27-14	[Signature]

UNLESS OTHERWISE SPECIFIED DIMENSIONS ARE IN INCHES	10 PERCENTS FRACTIONAL PLACE DEC ±0.1	DO NOT SCALE THIS DWG	MATERIAL
106-676-539	BL5000C-1	BL5000C-1	BL5000C-1
106-676-517	BL5000C-1	BL5000C-1	BL5000C-1
106-676-50X	BL5000C-X	BL5000C-X	BL5000C-X
106-676-451	BL4500C-1	BL4500C-1	BL4500C-1
NEXT ASSY	USED ON	APPLICATION	

**OUTLINE POWER CHASSIS**

106-977-514 (1 PHASE INPUT)